

# MAIN GROUP

4

## FRONT AXLE STEERING

	Illustration
01 Front axle beam (up to Chassis No. 115 999 000)	23
01 Front axle beam (from Chassis No. 116 000 001)	24
05 Front suspension (up to Chassis No. 115 999 000)	23
05 Front suspension (from Chassis No. 116 000 001)	24
07 Front suspension (from Chassis No. 111 2000 001)	25
11 Torsion spring (up to Chassis No. 115 999 000)	23
11 Torsion spring (from Chassis No. 116 000 001)	24
11 Springs, front (from Chassis No. 111 2000 001)	25
12 Shock absorber, front (from Chassis No. 111 2000 001)	25
13 Shock absorber (up to Chassis No. 115 999 000)	23
13 Shock absorber (from Chassis No. 116 000 001)	24
15 Steering (sector steering)	26
15 Steering (roller steering)	27
15 Steering (roller steering)	28
25 Steering damper	28
98 Repair kits	—



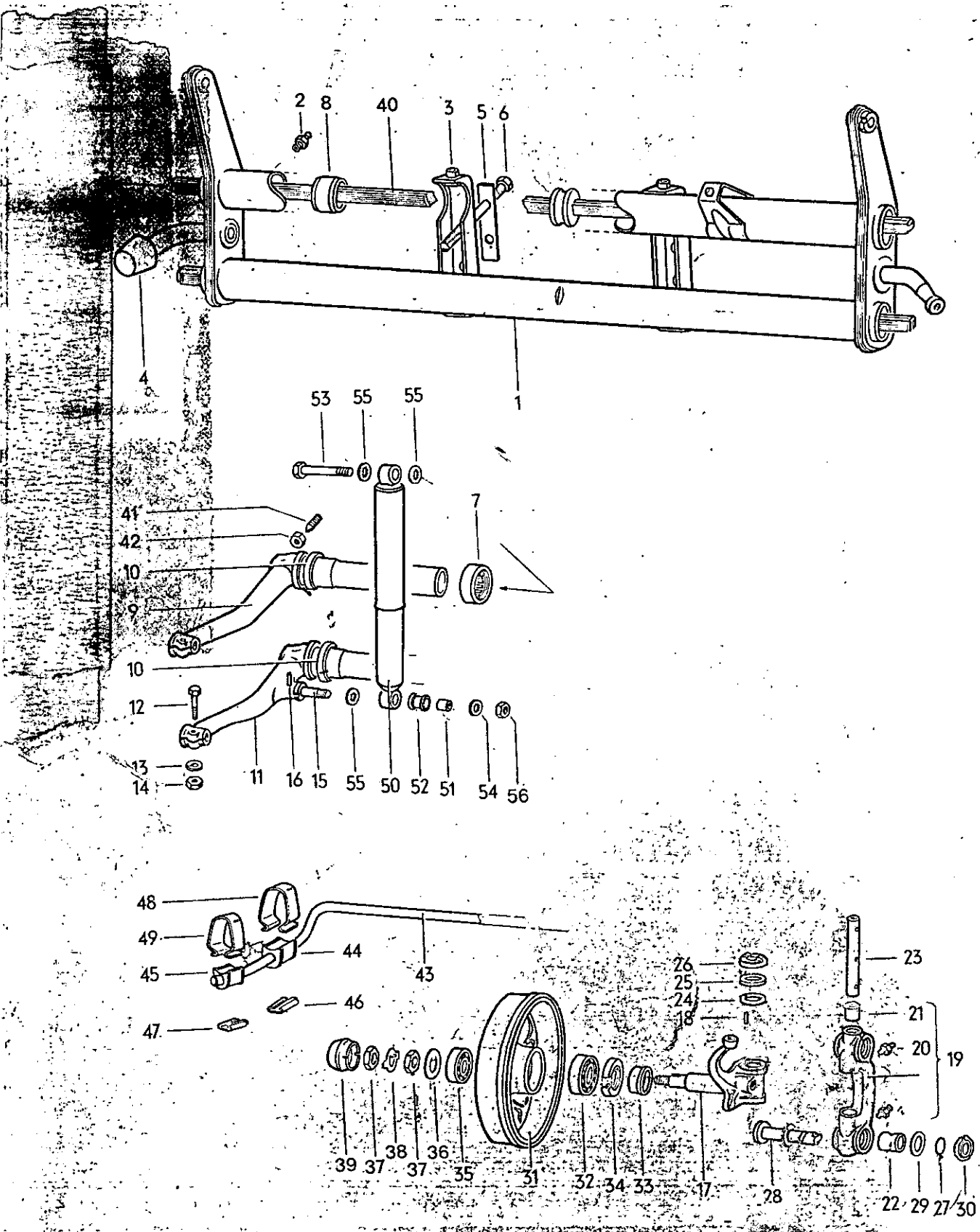

Key No.	Part No.	Description	Quantity	Type and model
<b>FRONT AXLE BEAM</b>				
up to Chassis No. 115 999 000				
				111-118, 141-144, 151, 152
1	113 401 021 A	Front axle beam with needle bearings ..... from Chassis No. 2 921 552	1	111, 113, 115, 117, 141, 143, 151
-	114 401 021 A	Front axle beam (RHD) with needle bearings .... from Chassis No. 2 921 552	1	112, 114, 116, 118, 142, 144, 152
-	111 401 025	Front axle beam ..... from Chassis No. 1 - 397 023 up to 2 921 551	1	
-	N 18 530 1	Grease nipple A 10 ..... up to Chassis No. 3 338 657	4	
2	N 18 516 1	Grease nipple A 8 ..... from Chassis No. 3 338 658	4	
3	111 401 161 A	Threaded bush - Front axle beam support ..... from Chassis No. 1 - 397 023 up to 3 192 506	2	
-	111 401 239	Caster wedge .....	2	
4	111 401 273	Stop (rubber) - Torsion arm .....	2	
5	*111 401 281	Lock plate - Front axle .....	2	
6	N 10 190 1 SSB-1 N 10 190 1	Bolt, hex. head M 12X1.5X90 .....	4	
7	111 401 301	Needle bearing 46.0 mm dia. - Torsion arm ..... from Chassis No. 2 921 552	4	
-	111 401 303	Needle bearing 46.2 mm dia. - Torsion arm ..... (oversize) from Chassis No. 2 921 552	x	
8	111 401 315	Bush - Torsion arm .....	4	

Key No.	Part No.	Description	Quantity	Type and model
<b>FRONT SUSPENSION</b>				
up to Chassis No. 115 999 000				
				111-118, 141-144, 151, 152
-	111 405 105 A	Torsion arm, upper ..... up to Chassis No. 1 - 117 053	2	111, 112
9	111 405 105 D	Torsion arm, upper ..... from Chassis No. 1 - 117 054	2	
10	111 405 129	Seal - Torsion arm .....	4	
11	111 405 151 C	Torsion arm, lower ..... from Chassis No. 1 - 117 054	2	
-	111 405 155 A	Torsion arm, lower ..... up to Chassis No. 1 - 117 053	2	111, 112
12	N 10 445 1	Bolt, hex. head M 10×45 .....	4	
13	N 12 010 2	Lock washer B 10 .....	4	
14	N 11 010 2	Nut, hex. M 10 .....	4	
15	111 405 175 A	Mounting bolt, lower - Shock absorber (oversize) x from Chassis No. 1 - 117 054	x	
16	N 12 825 1	Dowel pin grooved 4×25 .....	x	
17	111 405 301	Steering knuckle, left .....	1	
-	111 405 302	Steering knuckle, right .....	1	
18	N 13 206 1	Dowel pin 3×6 .....	2	
19	111 405 351	Link - Torsion arm (left) .....	1	
-	111 405 352	Link - Torsion arm (right) .....	1	
20	N 18 516 1	Grease nipple A 8 ..... from Chassis No. 3 338 658	4	
-	N 18 530 1	Grease nipple A 10 ..... up to Chassis No. 3 338 657	4	
21	111 405 391	Bush - King pin .....	4	

Key No.	Part No.	Description	Quantity	Type and model
22	*111 405 395 A	Bush - Torsion arm link pin	4	
23	*111 405 411	King pin	2	
24	111 405 486 A	Thrust washer 3.56 mm - King pin	x	
-	111 405 487 A	Thrust washer 3.63 mm - King pin	x	
-	111 405 488 A	Thrust washer 3.68 mm - King pin	x	
-	111 405 489 A	Thrust washer 3.73 mm - King pin	x	
-	111 405 490 A	Thrust washer 3.78 mm - King pin	x	
-	111 405 491 A	Thrust washer 3.83 mm - King pin	x	
-	111 405 492 A	Thrust washer 3.88 mm - King pin	x	
-	111 405 493 A	Thrust washer 3.93 mm - King pin	x	
-	111 405 494 A	Thrust washer 3.98 mm - King pin	x	
-	111 405 495 A	Thrust washer 4.03 mm - King pin	x	
-	111 405 496 A	Thrust washer 4.08 mm - King pin	x	
-	111 405 497	Thrust washer 4.30 mm - King pin	x	
-	111 405 498	Thrust washer 4.15 mm - King pin	x	
-	111 405 499	Thrust washer 4.22 mm - King pin	x	
25	*111 405 501	Thrust washer (fiber) - King pin	2	
26	*111 405 511	Cover - King pin thrust washer	2	
27	*111 405 517	Dust excluder - Torsion arm link pin from Chassis No. 2 921 552	4	
28	*111 405 521	Pin - Torsion arm-link	4	
29	*111 405 527	Shim - Torsion arm link pin	32	

Key No.	Part No.	Description	Quantity	Type and model
30	*111 405 537	Retainer – Dust excluder ..... from Chassis No. 2 921 552	4	
-	111 405 615	Brake drum, front (5 hole mounting) ..... up to Chassis No. 1 673 410 from Chassis No. 1 673 411 up to 4 630 937	2 2	111, 112, 115, 116
31	113 405 615 A	Brake drum, front (5 hole mounting) ..... from Chassis No. 1 673 411 up to 4 630 937  from Chassis No. 4 630 938	2  2	113, 114, 117, 118, 141-144, 151, 152
-	111 405 619	Tapped insert – Brake drum ..... x	x	
< 32	*111 405 625 A	Ball bearing, 62 mm dia. – Front wheel (inner) ... from Chassis No. 1 – 064 340	2	
33	*111 405 631 B	Spacer 40 mm dia. – Front wheel bearing (inner) from Chassis No. 1 – 064 340	2	
34	*111 405 641 A	Seal, 62 mm dia. – Front wheel bearing (inner) ... from Chassis No. 1 – 064 340	2	
Y 35	*111 405 645 A	Ball bearing, 52 mm dia. – Front wheel (outer) ... from Chassis No. 1 – 064 340	2	
-	111 405 649	Extractor ring ..... (for use with roller bearing only)	2	
36	*111 405 661	Thrust washer 38×20 – Front wheel bearing (outer)	2	
37	111 405 671	Nut, hex. – Steering knuckle, left .....	2	
-	111 405 672	Nut, hex. – Steering knuckle, right .....	2	
38	*111 405 681	Lock plate – Steering knuckle nut .....	2	
39	111 405 691	Grease cap – Front wheel ..... use: 311 405 381 for right only	2	

Key No.	Part No.	Description	Quantity	Type and model
		<b>TORSION SPRING</b> up to Chassis No. 115 999 000		111-118, 141-144, 151, 152
-	111 411 021	Torsion spring, lower (five leaves) ..... up to Chassis No. 1 - 117 053	1	111, 112
-	111 411 021 A	Torsion spring, lower (five leaves) ..... from Chassis No. 1 - 117 054 up to 1 - 138 834	1	111-118, 151, 152
-	111 411 021 A	Torsion spring (five leaves) ..... from Chassis No. 1 - 138 835 up to 1 - 397 022	2	111-118, 151, 152
-	111 411 023 A	Torsion spring, upper (four leaves) ..... from Chassis No. 1 - 117 054 up to 1 - 138 834	1	111-118, 151, 152
40	111 411 027	Torsion spring (eight leaves) ..... from Chassis No. 1 - 397 023	2	
41	111 411 151	Grub screw - Torsion spring mounting .....	6	
42	111 411 155	Nut - Grub screw .....	6	
43	113 411 309	Stabilizer .....	1	113, 114, 117, 118, 141-144, 151, 152
44	*141 411 313	Rubber cushion, large - Stabilizer .....	2	113, 114, 117, 118, 141-144, 151, 152
45	*141 411 317	Rubber cushion, small - Stabilizer .....	2	113, 114, 117, 118, 141-144, 151, 152
46	*141 411 323	Spring retaining clip, large .....	2	113, 114, 117, 118, 141-144, 151, 152
47	*141 411 327	Spring retaining clip, small .....	2	113, 114, 117, 118, 141-144, 151, 152
48	*141 411 333	Spring clip - large .....	2	113, 114, 117, 118, 141-144, 151, 152
49	*141 411 337	Spring clip - small .....	2	113, 114, 117, 118, 141-144, 151, 152

Key No.	Part No.	Description	Quantity	Type and model
<b>SHOCK ABSORBER</b>				
up to Chassis No. 115-999 000				111-118, 141-144, 151, 152
-	111 413 031	Shock absorber, front up to Chassis No. 1 - 117 053	2	111, 112
-	111 413 031 A	Shock absorber, front from Chassis No. 1 - 117 054 up to 1 - 397 022	2	111-118, 151, 152
-	111 413 031 G	Shock absorber, front (111 413 031 F/G, 113 413 031 J, 111 413 035 are supplied) from Chassis No. 1 - 397 023 up to 3 250 899	2	
-	111 413 031 N	Shock absorber, front (heavy duty) (111 413 031 M/N/Q are supplied) from Chassis No. 1 - 397 023	2	M 103
50	113 413 031 B to 65	Shock absorber, front (111 413 031 J/K/P 113 413 031 A/B/C/L are supplied) from Chassis No. 3 250 900	2	
-	211 413 031 B	Shock absorber, front (adjustable) from Chassis No. 1 - 397 023	2	
-	111 413 371	Bush - Rubber grommet for shock absorber 111 413 031 up to Chassis No. 1 - 117 053	4	111, 112
51	111 413 371 A	Bush - Rubber grommet for shock absorbers 111 413 031 A/F/G/J/K/N, 113 413 031 A/B from Chassis No. 1 - 117 054	4	
-	111 413 381	Grommet - Shock absorber 111 413 031 up to Chassis No. 1 - 117 053	4	111, 112
52	111 413 381 A	Grommet - Shock absorbers 111 413 031 A/F/G/J/K/N, 113 413 031 A/B from Chassis No. 1 - 117 054	4	
-	111 413 381 B	Grommet - Shock absorber 111 413 031 E	4	
-	111 413 391	Spacer - Shock absorber 111 413 031 N from Chassis No. 1 - 397 023	2	M 103
-	111 413 401	Bolt - Shock absorber 111 413 031 up to Chassis No. 1 - 117 053	2	111, 112



Key No.	Part No.	Description	Quantity	Type and model
- 43	111 413 401 A	Bolt - Shock absorbers 111 413 031 A/E/F/G/J/K, 113 413 031/A/B from Chassis No. 1 - 117 054 up to 4 846 835	2	
- 5	111 413 403 A	Bolt (oversize) - Shock absorbers 111 413 031 A/E/F/G/J/K, 113 413 031/A/B from Chassis No. 1 - 117 054 up to 4 846 835	2	
- f	111 413 401 B	Bolt - Shock absorber 111 413 031 N from Chassis No. 1 - 397 023 up to 4 846 835	2	M 103
- f	111 413 401 C	Bolt - Shock absorber 111 413 031 N from Chassis No. 4 846 836	2	M 103
- 5	211 513 411	Bolt (oversize) - Shock absorber 111 413 031 up to Chassis No. 1 - 117 053	2	111, 112
53	111 413 403 A	Bolt - Shock absorbers 111 413 031 A/E/F/G/J/K, 113 413 031/A/B from Chassis No. 4 846 836	2	
54	N 12 111 1	Spring washer J 10.5	2	
55	N 12 112 1	Spring washer J 12.5	6	
-	111 413 419	Spring washer - Shock absorber bolt for shock absorber 111 413 031 up to Chassis No. 1 - 117 053	4	111, 112
-	N 11 211 1	Nut, slotted M 10 up to Chassis No. 1 - 117 053	2	111, 112
-	N 12 522 1	Cotter pin 2x22 up to Chassis No. 1 - 117 053	2	111, 112
56	N 11 010 4	Nut, hex. M 10	2	

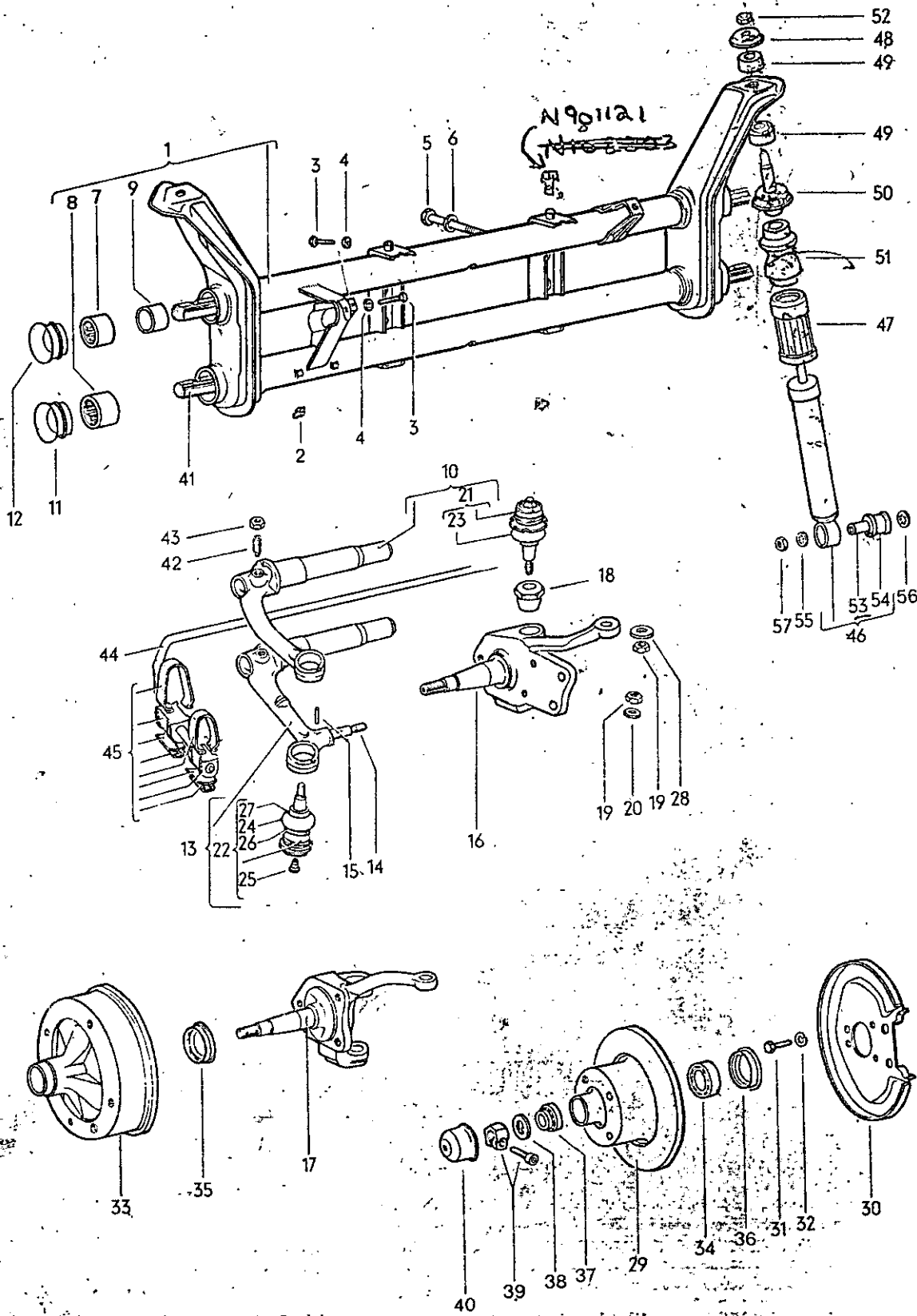

Key No.	Part No.	Description	Quantity	Type and model
<b>FRONT AXLE</b>				
		from Chassis No. 116 000 001 up to 110 3100 000		111-118, 141-144, 151, 152
		from Chassis No. 111 2000 001		111, 112, 115, 116, 141-144; M 1
113 400 025 K	*	Front axle without steering absorber (5 hole mounting, drum brakes) (up to Chassis No. 116 1021 300 for Types 111, 115 replace 311 415 413 by 131 415 413) up to Chassis No. 116 1021 300	1	111, 113, 115, 117, 141, 143, 151
		from Chassis No. 117 000 001 up to 117 999 000	1	111, 115; M 87, M 88, M 137: 113, 117, 151; M 129, M 139: 111, 115
113 400 025 AD		Front axle without steering absorber (4 hole mounting, disc brakes) replace for Types 141, 143: from Chassis No. 117 000 001 131 415 371 A by 141 415 371 E from Chassis No. 117 000 001 up to 110 3100 000	1	113, 117, 141, 143, 151; M 80
		from Chassis No. 111 2000 001 up to June 1971	1	M 1/M 80/M 87: 113, 117 M 1/M 80/M 88: 113, 117, 141, 143
113 400 025 AE	*	Front axle without steering absorber (4 hole mounting, drum brakes) from Chassis No. 118 000 001 up to 110 3100 000 from Chassis No. 118 000 001 from Chassis No. 111 2000 001	1 1 1	M 87, M 88, M 137, M 139 111, 115 M 1/M 87, M 1/M 88: 113, 117; M 1/M 137: 113, 117, 151
113 400 025 AJ		Front axle without steering damper (4 hole mounting, disc brakes) replace for models 141, 143: 131 415 371 A by 141 415 371 E from Chassis No. July 1971	1	M 1/M 80/M 87: 113, 117 M 1/M 80/M 88: 113, 117, 141, 143
114 400 025 J	*	Front axle without steering absorber (RHD) (5 hole mounting, drum brakes) (up to Chassis No. 116 1021 300 for Types 112, 116 replace 311 415 413 by 131 415 413) up to Chassis No. 116 1021 300	1	112, 114, 116, 118, 142, 144, 152
		from Chassis No. 117 000 001 up to 117 999 000	1	112, 116; M 87, M 88, M 137: 114, 118, 152; M 129, M 139: 112, 116



Key No.	Part No.	Description	Quantity	Type and model
-	114 400 025 AB	Front axle without steering absorber (RHD) ..... (4 hole mounting, disc brakes) replace for Types 142, 144: from Chassis No. 117 000 001 132 415 371 A by 142 415 371 E from Chassis No. 117 000 001 up to 110 3100 000	1	114, 118, 142, 144, 152: M 80
		from Chassis No. 111 2000 001 up to June 1971	1	M 1/M 80/M 87: 114, 118 M 1/M 80/M 88: 114, 118, 142, 144
-	114 400 025 AC *	Front axle without steering absorber (RHD) ..... (4 hole mounting, drum brakes) from Chassis No. 118 000 001 up to 110 3100 000 from Chassis No. 118 000 001 from Chassis No. 111 2000 001	1 1 1	M 87, M 88, M 137, M 139 112, 116 M 1/M 87, M 1/M 88: 114, 118; M 1/M 137: 114, 118, 152
-	114 400 025 AJ	Front axle without steering damper (RHD) ..... (4 hole mounting, disc brakes) replace for models 142, 144: 132 415 371 A by 142 415 371 E from Chassis No. July 1971	1	M 1/M 80/M 87: 114, 118. M 1/M 80/M 88: 114, 118, 142, 144
<b>FRONT AXLE BEAM</b>				
		from Chassis No. 116 000 001 up to 110 3100 000 from Chassis No. 111 2000 001		111-118, 141-144, 151, 152 111, 112, 115, 116, 141-144; M 1
1	113 401 021 D	Front axle beam .....	1	111, 113, 115, 117, 141, 143, 151
-	114 401 021 D	Front axle beam (RHD) .....	1	112, 114, 116, 118, 142, 144, 152
2	N 18 516 1	Grease nipple A 8 .....	4	
3	131 401 193	Bolt, hex. head M 8×25 – Steering stop .....	2	111-118
		up to Chassis No. 148 469 573	1	141, 143
-	N 10 244 1	Bolt, hex. head M 8×30 .....	2	142, 144
		from Chassis No. 148 469 574	1	141, 143
4	N 11 118 1	Nut, hex. BM 8 .....	2	
5	N 10 190 1	Bolt, hex. head M 12×1.5×90 .....	4	
6	N 12 012 2	Lock washer B 12 .....	4	
7	111 401 301	Needle bearing 46.0 mm dia. – Torsion arm upper	2	

Key No.	Part No.	Description	Quantity	Type and model
8	311 401 301 C	Needle bearing 50.0 mm dia. - Torsion arm lower	2	
-	311 401 301 D	Needle bearing 50.2 mm dia. - Torsion arm lower	X	
-	111 401 303	Needle bearing 46.2 mm dia. - Torsion arm upper	X	
9	131 401 313	Bush - Torsion arm	4	

FRONT SUSPENSION

from Chassis No. 116 000 001 up to 110 3100 000  
from Chassis No. 111 2000 001

111-118, 141-144, 151, 152  
111, 112, 115, 116, 141-144;  
M 1

10	131 405 103 A	Torsion arm with ball joint, upper, left	1	
-	131 405 104 A	Torsion arm with ball joint, upper, right	1	
11	131 405 129	Seal - Torsion arm, lower	2	
12	131 405 131	Seal - Torsion arm, upper	2	
13	131 405 151 A	Torsion arm with ball joint, lower, left	1	
-	131 405 152 A	Torsion arm with ball joint, lower, right	1	
14	111 405 175 A	Mounting bolt, lower - Shock absorber	X	
15	N 12 825 1	Dowel pin grooved 4X25	X	
16	113 405 311 D	Steering knuckle, left (disc brakes) from Chassis No. 117 000 001 use: from Chassis No. 117 000 000 up to 118 857 239; 311 405 625 A/641 B/311 415 811 C	1	113, 114, 117, 118, 141-144, 151, 152; M 80
17	113 405 311 E	Steering knuckle, left (drum brakes) up to Chassis No. 116 1021 300 from Chassis No. 117 000 001 up to 110 3100 000 from Chassis No. 117 000 001 (up to Chassis No. 118 857 239 use: 311 405 625 A/111 405 641 B/311 415 811 C)	1 1 1 1	M 137 111, 112, 115, 116; M 87 M 88, M 129, M 139

Key No.	Part No.	Description	Quantity	Type and model
-	113 405 312 D	Steering knuckle, right (disc brakes) ..... from Chassis No. 117 000 001 (up to Chassis No. 118 857 239 use: 311 405 625 A/641 B/311 415 812 C)	1	113, 114, 117, 118, 141-144, 151, 152; M 80
-	113 405 312 E	Steering knuckle, right (drum brakes) ..... up to Chassis No. 116 1021 300 from Chassis No. 117 000 001 up to 110 3100 000 from Chassis No. 117 000 001  (up to Chassis No. 118 857 239 use: 311 405 625 A/111 405 641 B/311 415 812 C)	1 1 1	M 137 111, 112, 115, 116; M 87, M 88, M 129, M 139
18	131 405 319	Eccentric bush - Steering knuckle .....	2	
-	411 399 149	Nut, hex. M 10×1 (self locking) ..... up to Chassis No. 116 372 332	4	
19	411 513 481	Lock washer M 12×1.5 (self locking) ..... from Chassis No. 116 372 333	4	
-	N 11 528 1	Washer B 10.5 ..... up to Chassis No. 116 372 332	2	
20	N 11 531 1	Washer 13 ..... from Chassis No. 116 372 333	2	
21	131 405 361 F	Ball joint, upper (38.3 mm knurling dia.) .....	2	
-	131 405 361 G	Ball joint, upper (38.6 mm knurling dia.) .....	x	
22	131 405 371 G	Ball joint, lower (38.3 mm knurling dia.) .....	2	
-	131 405 371 J	Ball joint, lower (38.6 mm knurling dia.) .....	x	
23	131 405 375 A	Seal - Ball joint, upper .....	2	
24	113 405 377	Seal - Ball joint, lower .....	2	
25	311 405 381	Plug - Ball joint .....	4	
-	131 405 385	Retaining ring 32 - Seal 131 405 375 .....	x	
26	111 415 837	Retaining ring 27 - Seal 131 405 377 .....	x	

Key No.	Part No.	Description	Quantity	Type and model
27	311 405 387 A	Retaining ring 13.8 – Seal .....	4	
-	131 405 423	Washer – Ball joint, upper .....	2	
		up to Chassis No. 116 372 332		
28	131 405 423 A	Washer – Ball joint, upper .....	2	
		from Chassis No. 116 372 333		
29	311 405 583 A	Brake disc .....	2	113, 114, 117, 118, 141-144, 151, 152; M 80
		from Chassis No. 117 000 001		
30	113 405 595	Splash shield .....	2	113, 114, 117, 118, 141-144, 151, 152; M 80
		from Chassis No. 117 000 001		
31	N 10 226 1	Bolt, hex. head M 7×10 .....	6	113, 114, 117, 118, 141-144, 151, 152; M 80
		from Chassis No. 117 000 001		
32	N 12 013 1	Lock washer B 7 .....	6	113, 114, 117, 118, 141-144, 151, 152; M 80
		from Chassis No. 117 000 001		
33	111 405 615 B	Brake drum, front (4 hole mounting) .....	2	M 137
		from Chassis No. 118 000 001 up to 110 3100 000	2	111, 112, 115, 116; M 87, M 88, M 139
		from Chassis No. 118 000 001		
-	113 405 615 D	Brake drum, front (4 hole mounting) .....	2	M 137
		from Chassis No. 111 2000 001		
-	131 405 615 A	Brake drum, front (5 hole mounting) .....	2	
		up to Chassis No. 116 1021 300	2	111, 112, 115, 116; M 87, M 88, M 129, M 137, M 139
		from Chassis No. 117 000 001 up to 117 999 000		
-	113 405 615 C	Brake drum, front (heavy duty) (5 hole mounting) .....	x	
		up to Chassis No. 116 1021 300	x	111, 112, 115, 116; M 87, M 88, M 129, M 137, M 139
		from Chassis No. 117 000 001 up to 117 999 000		
34	*311 405 625	Bearing, inner – Front wheel .....	2	
		up to Chassis No. 118 857 239		
-	*311 405 625 A	Bearing, inner – Front wheel .....	2	
		from Chassis No. 118 857 240		
35	*111 405 641 B	Oil seal – Front wheel bearing (drum bearings) .....	2	111, 112, 115, 116; M 87, M 88, M 129, M 137, M 139
		from Chassis No. 118 857 240		

Key No.	Part No.	Description	Quantity	Type and model
35	*131 405 641 A	Oil seal – Front wheel bearing (drum brakes) . . . . up to Chassis No. 116 1021 300 from Chassis No. 117 000 001 up to 118 857 239	2 2	111, 112, 115, 116; M 87, M 88, M 129, M 137, M 139
36	*311 405 641 A	Oil seal – Front wheel bearing (disc brakes) / . . . . . from Chassis No. 117 000 001 up to 118 857 239	2	113, 114, 117, 118, 141-144, 151, 152
-	*311 405 641 B	Oil seal – Front wheel bearing (disc brakes) . . . . . from Chassis No. 118 857 240	2	113, 114, 117, 118, 141-144, 151, 152; M 80
37	*311 405 645	Bearing, outer – Front wheel . . . . .	2	
38	*311 405 661	Thrust washer – Front wheel bearing . . . . .	2	
39	131 405 669	Clamping nut with screw – Wheel bearing, left . .	1	
-	131 405 670	Clamping nut with screw – Wheel bearing, right . .	1	
40	131 405 691	Grease cap – Front wheel . . . . . use: for right only 311 405 381	2	

**TORSION SPRINGS, FRONT**

from Chassis No. 116 000 001 up to 110 3100 000  
from Chassis No. 111 2000 001

111-118, 141-144, 151, 152  
111, 112, 115, 116, 141-144;  
M 1

41	131 411 107 A	Torsion spring (10 leaves) . . . . .	2	
42	111 411 151	Grub screw – Torsion spring mounting . . . . .	6	
43	111 411 155	Nut – Grub screw . . . . .	6	
44	131 411 309	Stabilizer . . . . .	1	
45	111 498 101 A	Set of stabilizer mounting parts for 1 side . . . . .	2	



Key No.	Part No.	Description	Quantity	Type and model
<b>SHOCK ABSORBER</b>				
		from Chassis No. 116 000 001 up to 110 3100 000		111-118, 141-144, 151, 152
		from Chassis No. 111 2000 001		111, 112, 115, 116, 141-144; M 1
46	113 413 031 E	Shock absorber, front ..... (113 413 031 D/E are supplied)	2	
-	113 413 031 M	Shock absorber, front (adjustable) .....	2	
-	113 413 035	Shock absorber, front (heavy duty) ..... (both shock absorbers of an axle must be identical)	2	M 103
47	131 413 425 A	Protection tube - Shock absorber .....	2	
48	131 413 431	Plate - Damping ring .....	2	
49	131 413 435	Damping ring - Shock absorber .....	4	
50	131 413 441	Bolt - Rubber stop .....	2	
51	131 413 449 B	Rubber stop - Front axle .....	2	
52	N 11 010 4	Nut, hex. M 10 .....	2	
53	111 413 371 A	Bush - Rubber grommet - ..... Shock absorber 113 413 031 M/035	2	
54	111 413 381 A	Rubber grommet - ..... Shock absorber 113 413 031 M/035	2	
55	N 12 111 1	Spring washer J 10.5 .....	2	
56	N 12 112 1	Spring washer J 12.5 .....	2	
57	N 11 010 2 SS 21 N 11010 11	Nut, hex. M 10 .....	2	

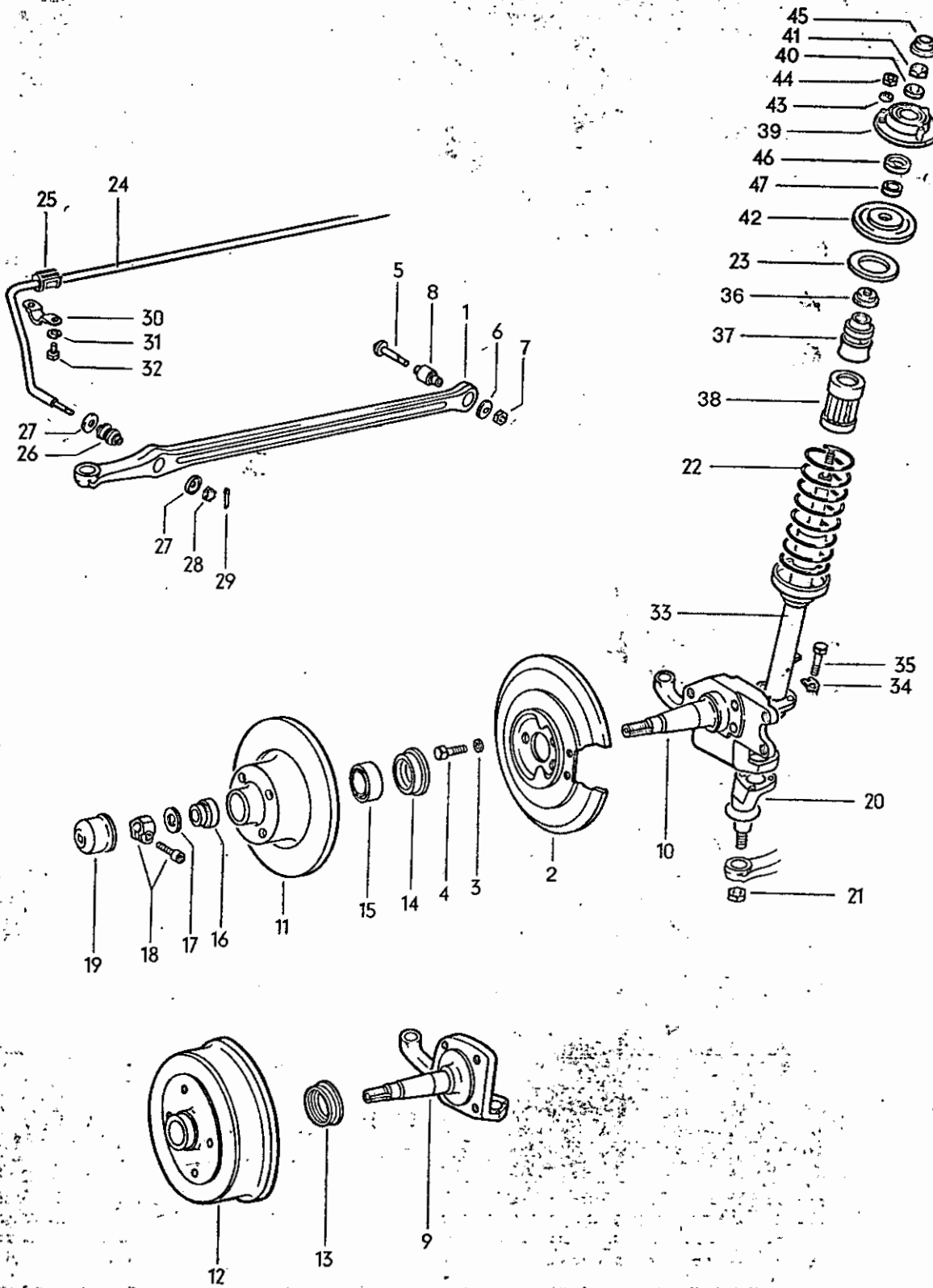

Key No.	Part No.	Description	Quantity	Type and model
<b>FRONT SUSPENSION</b>				
from Chassis No. 111 2000 001				
113, 114, 117, 118, 151, 152				
1	113 407 151 D	Track control arm .....	2	
2	113 407 165	Splash shield - Brake disc .....	2	
3	N 12 013 1	Lock washer B 7 .....	6	
4	N-10 226 1	Bolt, hex. head M 7×10 .....	6	
5	113 407 171	Eccentric screw .....	2	
6	113 407 177	Eccentric washer .....	2	
-	N 11 527 1	Washer B 10.5 .....	x	
7	411 399 149	Nut, hex. M 10×1 self-locking .....	2	
8	113 407 183 B	Bonded rubber mounting - Track control arm ...	2	
9	113 407 311 E *	Steering knuckle, left (drum brakes) .....	1	M 87, M 137
		(see Workshop Bulletin No. V-26/1971)		
10	113 407 311 F	Steering knuckle, left (disc brakes) .....	1	
		(see Workshop Bulletin No. V-26/1971)		
(9)	113 407 312 E *	Steering knuckle, right (drum brakes) .....	1	M 87, M 137
		(see Workshop Bulletin No. V-26/1971)		
(10)	113 407 312 F	Steering knuckle, right (disc brakes) .....	1	
		(see Workshop Bulletin No. V-26/1971)		
11	311 405 583 A	Brake disc .....	2	
12	113 405 615 D *	Brake drum, front (4 hole mounting) .....	2	M 87, M 137
13	111 405 641 B *	Seal - Front wheel bearing (drum brakes) .....	2	M 87, M 137
14	311 405 641 B	Seal - Front wheel bearing .....	2	
15	311 405 625 A	Bearing, inner - Front wheel .....	2	
16	311 405 645	Bearing, outer - Front wheel .....	2	

Key No.	Part No.	Description	Quantity	Type and model
17	311 405 661	Thrust washer - Front wheel bearing	2	
18	131 405 669	Clamping nut with screw for wheel bearing adjustment, left	1	
(18)	131 405 670	Clamping nut with screw for wheel bearing adjustment, right	1	
19	131 405 691	Grease cap (use 311 405 381 for right only)	2	
20	113 407 361 C	Ball joint	2	
21	411 513 481	Nut, hex. M 12x1.5 self-locking	2	

**FRONT SPRINGS**  
from Chassis No. 111 2000 001

113, 114, 117, 118, 151, 152

22	113 411 105	Coil spring - (marked red) 951 1 paint mark 952 2 paint marks 953 3 paint marks	2	
23	113 411 211	Damping ring - Coil spring	2	
24	113 411 309 D	Stabilizer	1	
25	113 411 313 A	Stabilizer mounting at frame	2	
26	113 411 315	Rubber mounting - Stabilizer	2	
27	113 411 319	Plate - Stabilizer mounting	4	
28	N 11 212 2	Nut, slotted M 12x1.5	2	
29	N 12 532 1	Cotter pin 3x25	2	
30	113 411 333	Clip - Stabilizer mounting	2	
31	N 12 008 2	Lock washer B 8	4	
32	N 10 244 7	Bolt, hex. head M 8x30	4	

SSBY  
1102448

Key No.	Part No.	Description	Quantity	Type and model
<b>FRONT SHOCK ABSORBERS</b>				
from Chassis No. 111 2000 001				113, 114, 117, 118, 151, 152; M 80
33	113 412 031 D	Shock absorber, front ..... from Chassis No. 111 2522 001	2	
-	113 412 031 E	Shock absorber, front (heavy duty) ..... from Chassis No. 111 2522 001	2	M 103: 113, 114, 117, 118, 151, 152
34	113 412 153	Lock plate - Hex. bolt .....	6	
35	N 10 448 2	Bolt, hex. head M 10x48 .....	6	
36	113 412 295	Seat - Rubber stop .....	2	
37	113 412 303 <i>sup B A</i>	Rubber stop - Front axle .....	2	
38	113 412 305	Protective tube - Shock absorber .....	2	
39	113 412 329 B	Suspension strut bearing .....	2	
40	N 11 534 1	Washer A 15 .....	2	
41	411 412 149	Nut, hex. M 15x1.5 self-locking .....	2	
42	113 412 339	Seat - Coil spring .....	2	
43	411 412 413	Washer - Suspension strut bearing .....	6	
44	113 415 431 A	Nut, hex. M 8 self-locking .....	6	
45	113 412 359 A	Cover - Suspension strut bearing .....	2	
46	113 412 361 A	Sealing washer - Suspension strut bearing .....	2	
47	113 412 365	Spacer ring - Suspension strut bearing .....	2	
-	113 412 367	Sealing washer - Suspension strut bearing .....	2	

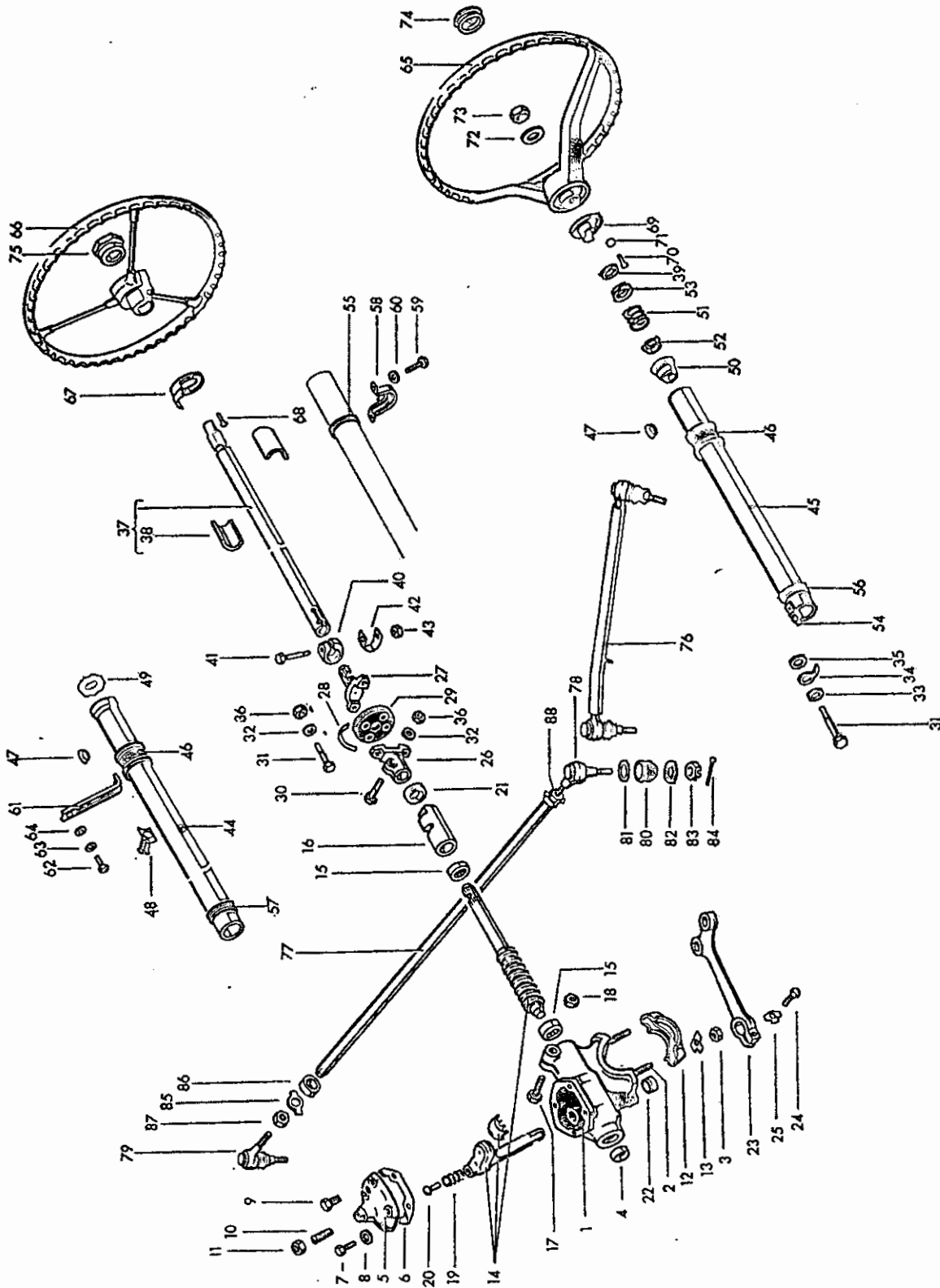

Key No.	Part No.	Description	Quantity	Type and model
<b>STEERING</b>				
<b>(Sector Type Steering)</b>				
		up to Chassis No. 3 933 184 for Home and Export markets		141-144, 151, 152
		up to Chassis No. 4 010 994 for Home market		113, 117
		up to Chassis No. 4 236 756 for Export market		113, 114, 117, 118
		up to Chassis No. 115 999 000		111, 112, 115, 116
1	113 415 061 C	Steering gear assy. .... use: 131 415 413	1	
2	N 14 461 1	Stud BM 10 B×58 .....	2	
3	N 11 010 4	Nut, hex. M 10 .....	2	
4	*111 415 115	Cap – Steering gear case .....	1	
5	111 415 131	Cover – Steering gear case .....	1	
6	*111 415 135	Gasket – Steering gear case cover .....	1	
7	N 10 242 5	Bolt, hex. head M 8×25 .....	4	
8	N 12 228 2	Spring washer B 8 .....	4	
9	111 101 193	Plug M 18×1.5 .....	1	
10	111 415 143	Adjusting screw – Sector shaft .....	1	
11	N 11 162 1	Nut, hex. M 12×1.5 .....	1	
12	131 415 155	Mounting clamp – Steering gear .....	1	
13	*111 415 159	Lock plate – Mounting clamp .....	2	
14	111 415 201	Steering gear set, comprising: Steering worm, ... sector, sector shaft 22 mm dia. up to Chassis No. 1 – 397 022	1	
15	111 415 227	Thrust bearing – Steering worm .....	2	

Key No.	Part No.	Description	Quantity	Type and model
16	111 415 251	Adjusting sleeve – Steering worm .....	1	
17	N 10 450 1	Bolt, hex. head M 10×50 .....	1	
18	N 11 010 4	Nut, hex. M 10 .....	1	
19	111 415 271 A	Spring – Sector shaft .....	1	
20	111 415 275	Pin – Spring .....	1	
21	*111 415 285 A	Sealing washer – Adjusting sleeve .....	1	
-	111 415 299	Sealing washer – Sector shaft 22 mm dia. .... up to Chassis No. 1 – 397 022	1	
22	N 14 902 1	Sealing washer A 28×40×7 – Sector shaft .....	1	
-	111 415 371	Steering drop arm (for sector shaft 22 mm dia.) .. up to Chassis No. 1 – 397 022	1	111, 113, 115, 117, 151
23	111 415 371 A	Steering drop arm (for sector shaft 28 mm dia.) .. from Chassis No. 1 – 397 023	1	111, 113, 115, 117, 151
-	112 415 371 A	Steering drop arm (RHD) .....	1	112, 114, 116, 118, 152
		for sector shaft 28 mm dia.) from Chassis No. 1 – 397 023		
-	141 415 371	Steering drop arm .....	1	141, 143
-	142 415 371	Steering drop arm (RHD) .....	1	142, 144
-	111 415 381	Bolt, hex. head – Steering drop arms .....	1	
		111 415 371/373 and 112 415 371/373 up to Chassis No. 1 – 397 022		
24	211 415 747 A	Bolt, hex. head – Steering drop arms .....	1	
		111 415 371 A/373 A and 112 415 371 A/373 A and 141/142 415 371 from Chassis No. 1 – 397 023		
25	*111 415 385	Lock plate .....	1	
26	111 415 409	Flange – Steering worm .....	1	



Key No.	Part No.	Description	Quantity	Type and model
-	131 415 413	Flange - Steering column .....	x	
27	311 415 413	Flange - Steering column .....	1	
28	111 971 246	Ground strap - Steering coupling .....	1	
		from Chassis No. 115 000 001		
29	111 415 417	Coupling disc (rubber) .....	1	
30	111 415 421	Bolt, hex. M 8×34 - Steering worm flange .....	1	
31	113 415 421	Bolt, hex. head M 8×32 - Steering coupling .....	4	
32	N 12 241 2	Spring washer B 8×15 .....	5	
33	N 12 108 2	Spring washer A 8.4 .....	1	113, 114, 117, 118, 141-144, 151, 152
34	113 971 935	Push-on connector - Coupling disc .....	1	113, 114, 117, 118, 141-144, 151, 152
35	N 11 526 2	Washer B 8.4 .....	1	113, 114, 117, 118, 141-144, 151, 152
-	N 12 522 1	Cotter pin 2×22 .....	4	
		up to Chassis No. 6 502 399		
36	113 415 431 A	Nut, hex. M 8 (self locking) .....	5	
-	N 12 241 2	Spring washer B 8×15 .....	1	
37	111 415 505 E	Steering column .....		
		up to Chassis No. 1 649 252	1	143
		up to Chassis No. 2 528 667	1	111-118, 151, 152
		from Chassis No. 2 528 668	1	111, 112, 115, 116
-	113 415 505 A	Steering column .....	1	113, 114, 117, 118, 141-144, 151, 152
		from Chassis No. 2 528 668 up to 4 010 994		
-	141 415 505	Steering column .....	1	141, 143
		from Chassis No. 1 649 253 up to 2 528 667		
-	113 415 515 C	Steering column (for export markets) .....	1	113, 114, 117, 118, 141-144, 151, 152
		from Chassis No. 4 010 995		
38	111 415 521 D	Locking shell .....	2	111-118, 151, 152

Key No.	Part No.	Description	Quantity	Type and model
-	113 415 527	Insulating sleeve – Steering column ..... from Chassis No. 2 528 668 up to 4 010 994	1	113, 114, 117, 118, 141-144, 151, 152
39	113 415 531	Lock ring – Steering column ..... from Chassis No. 2 528 668	1	113, 114, 117, 118, 141-144, 151, 152
-	113 415 533	Plastic washer between spring ..... and brass contact ring from Chassis No. 2 528 668 up to 4 010 994	1	113, 114, 117, 118, 141-144, 151, 152
40	111 415 539	Clamp – Steering column .....	1	
41	N 10 340.4	Bolt, hex. head M 8×40 .....	1	
42		no longer available superseded by: 113 415 431 A		
43	N 11 008 8	Nut, hex. M 8 .....	1	
44	111 415 555 B	Tube – Steering column ..... up to Chassis No. 2 528 667	1	111-118, 141, 143, 151, 152
		from Chassis No. 2 528 668	1	111, 112, 115, 116
45	113 415 559 C	Tube – Steering column ..... from Chassis No. 2 528 668	1	113, 114, 117, 118, 141-144, 151, 152
46	111 415 603 B	Rubber bush between steering column ..... tube and steering ignition lock	1	M 55: 111-118, 151, 152
47	111 415 609	Protective ring – Rubber bush 111 415 603 B .....	1	M 55: 111-118, 151, 152
-	211 881 895 A	Rubber plug between luggage compartment ..... and steering column tube from Chassis No. 2 528 668	1	113, 114, 117, 118, 141-144, 151, 152
48	111 415 571 A	Socket on steering column tube ..... up to Chassis No. 2 528 667	1	111-118, 141, 143, 151, 152
		from Chassis No. 2 528 668	1	111, 112, 115, 116
49	111 415 581 A	Bush 11 mm – Steering column tube ..... up to Chassis No. 2 528 667	1	111-118, 141, 143, 151, 152
		from Chassis No. 2 528 668	1	111, 112, 115, 116
-	113 415 585	Ball bearing – Steering column ..... from Chassis No. 2 528 668 up to 4 010 994	1	113, 114, 117, 118, 141-144, 151, 152

Key No.	Part No.	Description	Quantity	Type and model
50	113 415 585 A	Ball bearing – Steering column ..... from Chassis No. 4 010 995	1	113, 114, 117, 118, 141-144, 151, 152
51	113 415 587 A	Thrust spring ..... from Chassis No. 2 528 668	1	113, 114, 117, 118, 141-144, 151, 152
52	113 415 589 A	Thrust ring – Thrust spring ..... from Chassis No. 2 528 668	1	113, 114, 117, 118, 141-144, 151, 152
-	113 415 593	Washer ..... from Chassis No. 2 528 668 up to 4 010 994	1	113, 114, 117, 118, 141-144, 151, 152
53	113 415 593 A	Washer ..... from Chassis No. 4 010 995	1	113, 114, 117, 118, 141-144, 151, 152
54	113 415 595	Riveted push-on connection – ..... Steering column tube from Chassis No. 3 192 507	1	113, 114, 117, 118, 141-144, 151, 152
55	111 415 603	Rubber mounting, upper – Steering column tube	1	
56	111 415 607	Rubber mounting, lower – Steering column tube	1	113, 114, 117, 118, 141-144, 151, 152
57	131 415 607	Rubber mounting, lower – Steering column tube	1	111, 112, 115, 116
58	111 415 611	Clamp – Steering column tube .....	1	
59	N 10 215 4	Bolt, hex. head M 6×15 .....	2	
60	N 11 652 1	Washer 7 .....	2	
61	111 415 621 F	Support – Steering column ..... from Chassis No. 1 600 440	1	111-118, 151, 152
62	N 10 210 7	Bolt, hex. head M 6×10 K .....	1	
63	N 12 006 2	Lock washer B 6 .....	1	
64	N 11 695 2	Washer 6.1 .....	1	
-	113 415 651 A	Steering wheel ..... up to Chassis No. 1 649 252 up to Chassis No. 2 528 667	1 1 1	141, 143 113, 114, 117, 118, 151, 152 M 1, M 110: 111, 112, 115, 116
	1/50 - 7/65	466 silver beige		

Key No.	Part No.	Description	Quantity	Type and model
-	113 415 651 D	Steering wheel ..... from Chassis No. 1 649 253 up to 4 010 994 use: from Chassis No. 1 649 253 up to 2 528 667 for models 141, 143; 113 415 505 A		
	8/57 - 7/59	466 silver beige	1	141, 143
	8/59 - 7/61	466 silver beige - 57, 58, 59, 60, 61, 62, 74, 75, 76, 77, 78	1	113, 114, 117, 118, 141-144, 151, 152
	8/60 - 7/61	984 soft beige - 63, 80	1	141-144
65	311 415 651 D	Steering wheel ..... from Chassis No. 4 010 995 up to 4 236 756	1	113, 114, 117, 118
	8/61 - 11/61	043 grey-black		
66	111 415 655 A	Steering wheel ..... 041 black 466 silver beige	1	111, 112, 115, 116
	1/47 - 7/63			
	8/63 - 7/65			
67	111 415 657	Self-cancelling ring - Flashing indicator switch ... from Chassis No. 3 192 507	1	111, 112, 115, 116
-	113 415 657	Self-cancelling ring - Flashing indicator switch ... up to Chassis No. 2 528 667	1	113, 114, 117, 118, 141, 143, 151, 152
68	N 10 901 2	Screw, countersunk head AM 3×8 .....	2	
-	113 415 657 A	Self-cancelling ring - Direction indicator switch ... from Chassis No. 2 528 668 up to 4 010 994	1	113, 114, 117, 118, 141-144, 151, 152
69	113 415 661 B	Self-cancelling ring - Flashing indicator switch ... from Chassis No. 4 010 995	1	113, 114, 117, 118, 141-144, 151, 152
-	113 415 665	Insulating washer for self-cancelling ring ..... from Chassis No. 2 528 668	3	113, 114, 117, 118, 141-144, 151, 152
70	N 10 803 2	Screw, fillister head M 3.5×10 .....	3	113, 114, 117, 118, 141-144, 151, 152
71	N 12 131 2	Shake-proof washer J 3.7 .....	3	113, 114, 117, 118, 141-144, 151, 152
72	N 12 239 1	Spring washer B 18 ..... from Chassis No. 2 528 668	1	113, 114, 117, 118, 141-144, 151, 152
73	N 11 165 3	Nut, hex. M 18×1.5 ..... from Chassis No. 2 528 668	1	113, 114, 117, 118, 141-144, 151, 152

Key No.	Part No.	Description	Quantity	Type and model
74	113 415 669 B	Emblem – Horn ring ..... from Chassis No. 2 528 668	1	113, 114, 117, 118, 141-144, 151, 152
75	111 415 691	Nut – Steering wheel ..... up to Chassis No. 2 528 667	1	111-118, 141, 143, 151, 152
		from Chassis No. 2 528 668	1	111, 112, 115, 116
76	111 415 801 C	Tie rod, left .....	1	111, 113, 115, 117, 151
–	112 415 801 D	Tie rod, left, adjustable (RHD) ..... up to Chassis No. 2 921 551	1	112, 116
			1	114, 118, 152
–	114 415 801 A	Tie rod, left, adjustable (RHD) ..... up to Chassis No. 2 921 551	1	142, 144
–	114 415 801 A	Tie rod, left, adjustable – Steering damper (RHD) from Chassis No. 2 921 552 up to 4 010 994	1	114, 118, 142, 144, 152
–	114 415 801 C	Tie rod, left, adjustable (RHD) ..... from Chassis No. 4 010 995	1	114, 118
–	141 415 801 A	Tie rod, left .....	1	141, 143
		up to Chassis No. 4 010 994		
77	311 415 802	Tie rod, right, adjustable ..... up to Chassis No. 2 921 551	1	111, 113, 115, 117, 151
		from Chassis No. 2 921 552	1	111, 115
–	112 415 802 C	Tie rod, right (RHD) ..... up to Chassis No. 4 010 994	1	112, 114, 116, 118, 142, 144, 152
		from Chassis No. 4 010 995	1	112, 114, 116, 118
–	113 415 802 B	Tie rod, right, adjustable ..... from Chassis No. 2 921 552	1	113, 117, 151
–	141 415 802 B	Tie rod, right, adjustable – Steering damper ..... up to Chassis No. 4 010 994	1	141, 143
–	111 415 811	Tie rod end (round head) with left-hand thread ..	1	111, 113, 115, 117, 151
–	112 415 811	Tie rod end (round head) with left-hand thread .. (RHD)	1	112, 114, 116, 118, 151

Key No.	Part No.	Description	Quantity	Type and model
78	131 415 811	Tie rod end, straight, left-hand thread .....	1	
-	111 415 812	Tie rod end (round head) .....	1	
-	113 415 812 A	Tie rod end (flat head) ..... Tie rod for steering damper	1	113, 117, 141, 143, 151
79	131 415 812	Tie rod end, straight, right-hand thread .....	4	
-	113 415 813	Tie rod end for steering damper ..... with left-hand thread	1	114, 118, 142, 144, 152
-	113 415 821	Tie rod end, angled, right-hand thread .....	1	113, 114, 117, 118, 141-144, 151, 152
-	N 18 516 1	Grease nipple A 8 .....	2	
-	N 18 511 2	Grease nipple C 8 .....	2	
-	N 18 515 1	Grease nipple A 6 .....	2	
-	N 18 512 1	Grease nipple C 6 .....	2	
-	211 415 835	Dust seal - Tie rod end .....	4	111-118, 151, 152
-	111 415 835 A	Dust seal - Tie rod end .....	4	
80	113 415 835	Dust seal - Tie rod end .....	4	
81	111 415 837	Retaining ring 27 mm dia. - Dust seal .....	4	
82	113 415 837	Retaining ring 8.2 mm dia. - Dust seal .....	4	
83	N 11 210 1	Nut, slotted M 10×1 .....	4	
84	N 12 522 1	Cotter pin 2×22 .....	4	
-	111 415 841 A	Clamp 18 mm dia. - Tie rod ..... 112 415 801 A/111 415 802	2	111-118, 151, 152
-	N 10 171 1	Bolt, hex. head M 8×1×32 .....	2	

Key No.	Part No.	Description	Quantity	Type and model
-	N 12 008 2	Lock washer B 8 .....	2	
-	N 11 018 2	Nut, hex. M 8×1 .....	2	
85	141 415 851 B	Lock plate .....	2	
86	141 415 855 A	Taper ring .....	2	
87	N 11 163 3	Nut, hex. M 14×1.5 .....	1	
88	N 11 163 2	Nut, hex. M 14×1.5 left-hand thread .....	1	
-	113 425 021 A	Steering damper .....	1	113, 114, 117, 118,
		from Chassis No. 2 921 552 up to 4 010 994		142, 144, 151, 152
		from Chassis No. 4 010 995	1	113, 117
-	113 425 021	Steering damper .....	1	141, 143
		from Chassis No. 2 921 552 up to 4 010 994	1	114, 118
		from Chassis No. 4 010 995		
-	N 11 134 2	Nut, hex. M 10 .....	2	113, 114, 117, 118,
				141-144, 151, 152
-	113 415 907 C	Rubber grommet – Steering damper .....	2	113, 114, 117, 118,
		113 415 901/A; 114/141 415 901/113 425 021		141-144, 151, 152
-	211 415 907 C	Rubber grommet – Steering damper .....	2	113, 114, 117, 118,
		113 415 901 B/113 425 021 A		142, 144, 151, 152
-	211 415 909	Bush – Rubber grommet .....	2	113, 114, 117, 118,
				141-144, 151, 152
-	111 415 921	Clip – Steering damper (service installation) .....	1	
-	N 10 242 5	Bolt, hex. head M 8×25 .....	1	
-	N 12 008 2	Lock washer B 8 .....	1	
-	N 11 008 8	Nut, hex. M 8 .....	1	
-	113 415 949	Lock plate – Steering damper .....	1	113, 114, 117, 118,
				141-144, 151, 152
-	N 10 440 1	Bolt, hex. head M 10×40 .....	1	113, 114, 117, 118,
				141-144, 151, 152

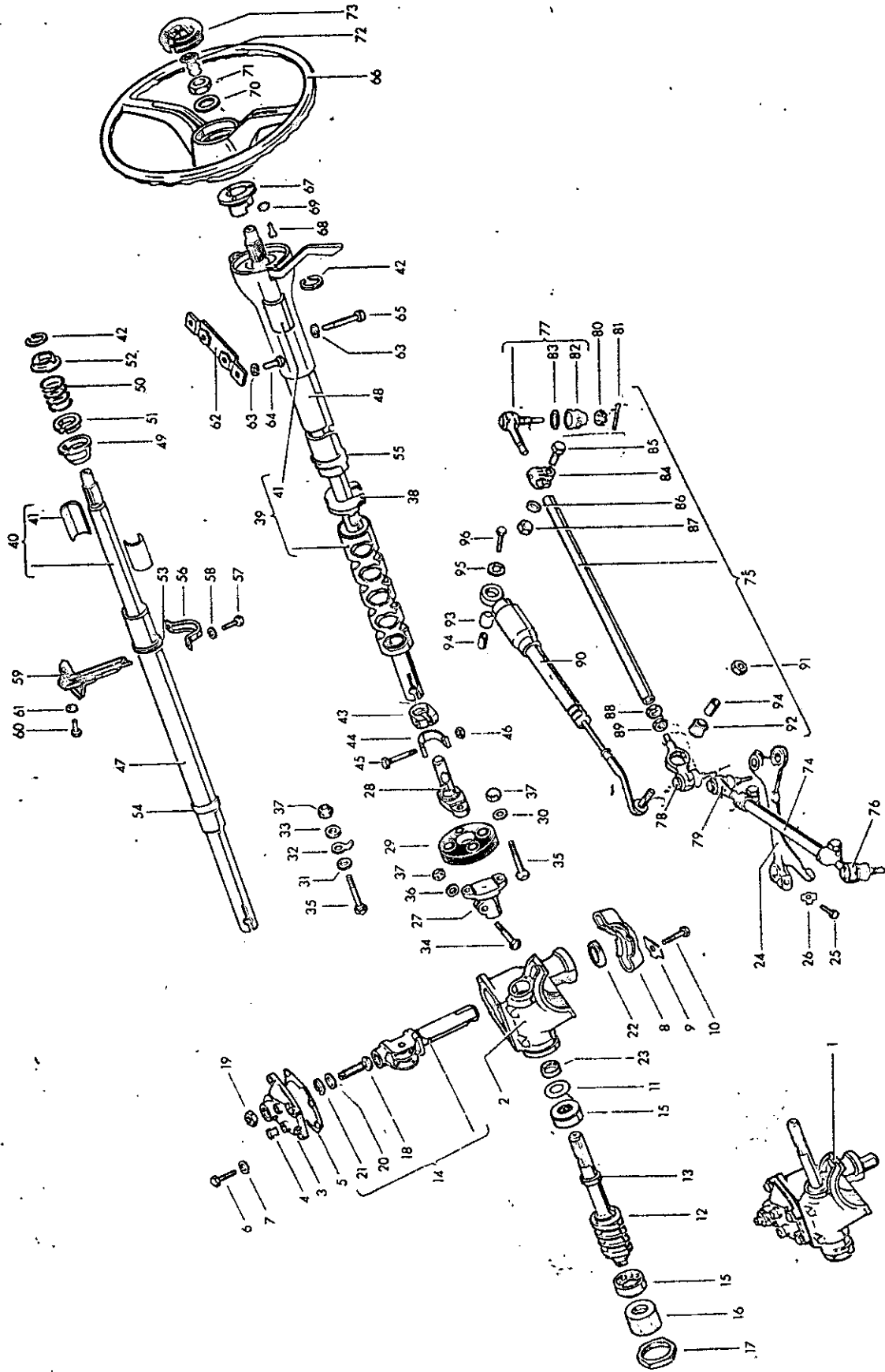



Key No.	Part No.	Description	Quantity	Type and model
<b>STEERING</b>				
<b>(Roller Type Steering)</b>				
		from Chassis No. 3 933 185 up to 110 3100 000		151, 152
		from Chassis No. 4 010 995 up to 110 3100 000		113, 117
		for Home market		
		from Chassis No. 4 236 757 up to 110 3100 000		113, 114, 117, 118
		for Export market		
		from Chassis No. 3 933 185		141-144
		from Chassis No. 116 000 001		111, 112, 115, 116
		from Chassis No. 111 2000 001		M 1
1	113 415 061 C	Steering gear assy. ....	1	
2	311 415 105 A	Case - Steering gear ..... use: up to Chassis No. 111 2517 787 311 415 129 B, 311 415 135 A	1	
3	311 415 129 B	Cover - Steering gear case .....	1	
4	311 415 133	Retaining plug - Steering gear case cover ..... 311 415 129 A	2	
-	311 415 135	Gasket - Steering gear case cover ..... up to Chassis No. 111 2517 787	1	
5	311 415 135 A	Gasket - Steering gear case cover ..... from Chassis No. 111 2517 788	1	
6	N 10 240 4	Bolt, hex. head M 8X20 ..... up to Chassis No. 111 2517 787	4	
7	N 12 241 2	Spring washer B 8X15 ..... up to Chassis No. 111 2517 787	4	
-	N 10 242 5	Bolt, hex. head M 8X25 ..... from Chassis No. 111 2517 788	4	
-	N 12 228 2	Spring washer B 8 ..... from Chassis No. 111 2517 788	4	
-	311 415 139	Plug M 14X1.5 - Steering gear case cover ..... 311 415 129	1	
8	131 415 155	Mounting clamp - Steering gear .....	1	
9	111 415 159	Lock plate - Mounting clamp .....	2	

Key No.	Part No.	Description	Quantity	Type and model
-	N 11 010 4	Nut, hex. M 10 ..... up to Chassis No. 6 050 836	2	
10	N 10 448 2	Bolt, hex. head M 10×48 ..... from Chassis No. 6 050 837	2	
11	311 415 193	Shim 0.20 mm – Steering worm .....	x	
-	311 415 194	Shim 0.25 mm – Steering worm .....	x	
-	311 415 195	Shim 0.30 mm – Steering worm .....	x	
-	311 415 196	Shim 0.35 mm – Steering worm .....	x	
-	311 415 197	Shim 0.40 mm – Steering worm .....	x	
-	311 415 198	Shim 0.45 mm – Steering worm .....	x	
-	311 415 199	Shim 0.50 mm – Steering worm .....	x	
12	311 415 205	Steering worm .....	1	
13	311 415 213	Identification ring – Steering worm .....	x	
14	311 415 217 B	Steering roller shaft .....	1	
15	411 417 225	Ball bearing – Steering worm .....	2	
16	311 415 251	Adjusting screw – Steering worm .....	1	
17	311 415 261	Lock nut – Adjusting screw .....	1	
18	113 415 263	Adjusting screw – Steering roller shaft .....	1	
19	N 11 157 1	Nut, hex. M 10×1 .....	1	
20	311 415 265	Shim 2.00 mm – Steering roller shaft .....	x	
-	311 415 266	Shim 2.05 mm – Steering roller shaft .....	x	
-	311 415 267	Shim 2.10 mm – Steering roller shaft .....	x	
-	311 415 268	Shim 2.15 mm – Steering roller shaft .....	x	
-	311 415 269	Shim 2.20 mm – Steering roller shaft .....	x	
-	311 415 270	Shim 2.25 mm – Steering roller shaft .....	x	

Key No.	Part No.	Description	Quantity	Type and model
21	N 12 307 1	Lockring 17X1 .....	1	
22	N 14 905 1	Seal A 24X37X7 – Steering roller shaft .....	1	
23	311 415 277	Seal – Steering worm .....	1	
-	113 415 371	Steering drop arm .....	1	113, 117, 151
		up to Chassis No. 115 999 000		
24	131 415 371	Steering drop arm .....	1	111, 113, 115, 117, 151
		from Chassis No. 116 000 001 up to 118 857 239		
-	131 415 371 A	Steering drop arm .....	1	111, 113, 115, 117, 151
		from Chassis No. 118 857 240		
-	114 415 371	Steering drop arm .....	1	114, 118, 152
		up to Chassis No. 115 999 000		
-	132 415 371	Steering drop arm .....	1	112, 114, 116, 118, 152
		from Chassis No. 116 000 001 up to 118 857 239		
-	132 415 371 A	Steering drop arm .....	1	112, 114, 116, 118, 152
		from Chassis No. 118 857 240		
-	141 415 371 A	Steering drop arm .....	1	141, 143
		up to Chassis No. 115 999 000		
-	141 415 371 B	Steering drop arm .....	1	141, 143
		from Chassis No. 116 000 001 up to 118 857 239		
-	141 415 371 E	Steering drop arm .....	1	141, 143
		from Chassis No. 118 857 240		
-	142 415 371 A	Steering drop arm .....	1	142, 144
		up to Chassis No. 115 999 000		
-	142 415 371 B	Steering drop arm .....	1	142, 144
		from Chassis No. 116 000 001 up to 118 857 239		
-	142 415 371 E	Steering drop arm .....	1	142, 144
		from Chassis No. 118 857 240		
25	211 415 747 A	Bolt, hex. head – Steering drop arm .....	1	
26	111 415 385	Lock plate .....	1	
27	111 415 409	Flange, lower – Steering worm .....	1	
-	131 415 413	Flange, upper – Steering column .....	1	111, 112, 115, 116
		from Chassis No. 116 000 001 up to 116 1021 300		

Key No.	Part No.	Description	Quantity	Type and model
28	311 415 413	Flange, upper – Steering column up to Chassis No. 116 1021 300	1	113, 114, 117, 118, 141-144, 151, 152
		from Chassis No. 117 000 001	1	
29	111 415 417	Coupling disc (rubber)	1	
30	N 12 228 2	Spring washer B 8	3	
31	N 12 108 2	Spring washer A 8.4	1	
32	113 971 935	Push-on connector – Coupling disc	1	
33	N 11 526 2	Washer B 8.4	1	
34	111 415 421	Bolt, hex. head M 8×34 – Steering worm flange	1	
35	113 415 421	Bolt, hex. head M 8×32 – Coupling disc	4	
36	N 12 241 2	Spring washer B 8×15	1	
37	113 415 431 A	Nut, hex. M 8 (self locking)	5	
38	311 415 475	Thrust ring – Steering column from Chassis No. 118 000 001 up to 110 3100 000	1	
–	113 415 501	Steering column with locking shell from Chassis No. 118 000 001 up to 110 3100 000	1	
39	113 415 501 C	Steering column with locking shells from Chassis No. 111 2000 001 up to 111 3200 000 from Chassis No. 112 2000 001	1	111, 112, 115, 116
–	113 415 501 D	Steering column with locking shells from Chassis No. 112 2000 001	1	M 1: 113, 114, 117, 118, 141-144; M 108, M 110
–	111 415 505 E	Steering column with locking shells from Chassis No. 116 000 001 up to 116 1021 300	1	111, 112, 115, 116; M 1, M 11, M 110
40	113 415 505 E	Steering column with locking shells up to Chassis No. 116 1021 300	1	113, 114, 117, 118, 141-144, 151, 152
		from Chassis No. 117 000 001 up to 117 999 000	1	111-118, 151, 152
–	141 415 505 A	Steering column with locking shells from Chassis No. 117 000 001 up to 117 999 000	1	M 55: 141-144
41	111 415 521 D	Locking shell up to Chassis No. 116 1021 300	2	113, 114, 117, 118, 141-144, 151, 152
		from Chassis No. 117 000 001	2	

Key No.	Part No.	Description	Quantity	Type and model
42	113 415 531	Lock ring – Steering column .....	1	113, 114, 117, 118, 141-144, 151, 152
		up to Chassis No. 116 1021 300		
		from Chassis No. 117 000 001	1	
43	111 415 539	Clamp – Steering column .....	1	
44		no longer available superseded by: 113 415 431 A		
45	N 10 340 4	Bolt, hex. head M 8×40 .....	1	
46	N 11 008 8	Nut, hex. M 8 .....	1	
		up to Chassis No. 110 3100 000		
-	113 415 431 A	Nut, hex. M 8 self-locking .....	1	
		from Chassis No. 111 2000 001		
-	111 415 555 B	Tube – Steering column .....	1	111, 112, 115, 116
		from Chassis No. 116 000 001 up to 116 1021 300		
-	111 415 555 D	Tube – Steering column .....	1	111, 112, 115, 116, 141-144; M 1; M 108, M 110
		from Chassis No. 111 2000 001 up to 111 3200 000		
-	111 415 555 E	Tube – Steering column .....	1	111, 112, 115, 116, 141-144; M 1; M 108, M 110
		from Chassis No. 112 2000 001		
47	113 415 559 C	Tube – Steering column .....	1	113, 114, 117, 118, 141-144, 151, 152
		up to Chassis No. 116 1021 300		
		from Chassis No. 117 000 001 up to 117 999 000	1	
48	113 415 565 F	Tube – Steering column .....	1	
		from Chassis No. 118 000 001 up to 110 3100 000		
-	N 20 022 3	Plug (rubber) A 8×1 .....	1	
		from Chassis No. 118 000 001		
-	211 881 895 A	Rubber pad between tube and luggage compartment .....	1	
		from Chassis No. 115 000 001		
-	311 415 573	Seal – Steering column tube .....	1	
		from Chassis No. 110 2000 001 up to 110 3100 000		
-	111 415 581 A	Bush 11 mm – Steering column tube .....	1	111, 112, 115, 116
		from Chassis No. 116 000 001 up to 116 1021 300		

Key No.	Part No.	Description	Quantity	Type and model
49	113 415 585 A	Ball bearing – Steering column ..... up to Chassis No. 116 1021 300	1	113, 114, 117, 118, 141-144, 151, 152
		from Chassis No. 117 000 001 up to 117 999 000	1	
50	113 415 587 A	Thrust spring ..... up to Chassis No. 116 1021 300	1	113, 114, 117, 118, 141-144, 151, 152
		from Chassis No. 117 000 001 up to 117 999 000	1	
51	113 415 589 A	Thrust ring – Thrust spring ..... up to Chassis No. 116 1021 300	1	113, 114, 117, 118, 141-144, 151, 152
		from Chassis No. 117 000 001 up to 117 999 000	1	
-	111 415 591	Intermediate support for column tube mounting (Only if 111 805 051 BB, 112 805 051 AR, 113 805 051 AQ or 114 805 051 AQ is installed in vehicles up to Chassis No. 117 999 000)	1	
52	113 415 593 A	Washer ..... up to Chassis No. 116 483 102	1	
53	111 415 603	Rubber mounting, upper – Steering column tube up to Chassis No. 117 999 000	1	111-118, 151, 152
-	111 415 603 B	Rubber bush between steering column tube and steering ignition lock from Chassis No. 147 000 001 up to 147 999 000	1	M 55: 111-118, 151, 152 M 55: 141-144
54	131 415 607	Rubber mounting, lower – Steering column tube up to Chassis No. 117 999 000	1	
55	113 415 607 A	Rubber mounting – Steering column tube ..... from Chassis No. 118 000 001	1	
-	311 415 607	Rubber mounting, lower – Steering column tube .. (Only if 113 415 559 C, 111 805 451 B, 113 805 451 B or 114 805 451 is installed)	1	
-	111 415 609	Protective ring – Rubber bush 111 415 603 B ..... up to Chassis No. 117 999 000	1	M 55: 111-118, 151, 152
56	111 415 611	Clamp – Steering column tube ..... up to Chassis No. 117 999 000	1	111-118, 151, 152
-	131 415 611	Clamp – Steering column tube ..... from Chassis No. 147 000 001 up to 147 999 000	1	141-144

Key No.	Part No.	Description	Quantity	Type and model
-	131 415 611 A	Clamp - Steering column tube ..... from Chassis No. 147 000 001 up to 147 999 000	1	M 55: 141-144
57	N 10 215 4	Bolt, hex. head M 6×15 ..... up to Chassis No. 117 999 000	2	
-	N 10 216 8	Bolt, hex. head M 6×18 ..... up to Chassis No. 117 999 000	2	M 55: 141-144
58	N 11 652 1	Washer 7 ..... up to Chassis No. 117 999 000	2	
-	131 415 615	Rubber mounting, upper - Steering column tube from Chassis No. 147 000 001 up to 147 999 000	1	141-144
-	131 415 615 A	Rubber mounting between steering column ..... tube and steering-ignition lock from Chassis No. 147 000 001 up to 147 999 000	1	M 55: 141-144
-	111 415 619 C	Packing - Steering column tube mounting ..... from Chassis No. 111 2000 001	2	111, 112, 115, 116, 141-144; M 1
-	111 415 621 F	Support - Steering column ..... up to Chassis No. 117 999 000	1	111-118, 151, 152
59	111 415 621 G	Support - Steering column ..... from Chassis No. 118 000 001	1	111-118, 151, 152
60	N 10 210 7	Bolt, hex. head M 6×10 K ..... up to Chassis No. 117 999 000	2	111-118, 151, 152
61	211 805 243	Spring washer 6 ..... up to Chassis No. 117 999 000	2	111-118, 151, 152
62	111 415 635	Mounting plate - Steering column tube ..... from Chassis No. 111 2000 001 up to 111 3200 000	1	111, 112, 115, 116, 141-144; M 1
-	N 11 525 2	Washer A 8.4 ..... from Chassis No. 111 2000 001	2	111, 112, 115, 116, 141-144; M 1
-	N 12 241 2	Spring washer B 8×15 ..... from Chassis No. 111 2000 001	2	111, 112, 115, 116, 141-144; M 1
-	N 14 707 2	Screw, cheese head M 8×12 ..... from Chassis No. 111 2000 001	2	111, 112, 115, 116, 141-144; M 1
-	113 415 635	Mounting plate - Steering column tube ..... from Chassis No. 118 000 001 up to 110 3100 000	2	

Key No.	Part No.	Description	Quantity	Type and model
-	111 857 779	Rubber washer between mounting plate ..... and instrument panel from Chassis No. 148 000 001 up to 141 3200 000	x	141-144
63	N 12 008 2	Lock washer B 8 ..... from Chassis No. 118 000 001 up to 110 3100 000 from Chassis No. 111 2000 001 up to 111 3200 000	4 2	111, 112, 115, 116, 141-144; M 1
64	N 10 238 7	Bolt, hex. head M 8x15 ..... from Chassis No. 118 000 001 up to 111 3200 000	2	
65	N 14 713 2	Screw, cheese head M 8x35 ..... from Chassis No. 118 000 001 up to 110 3100 000	2	
-	111 415 651 E	Steering wheel ..... from Chassis No. 111 2000 001 up to 111 3200 000 from Chassis No. 112 2000 001 043 grey black	1 1	111, 112, 115, 116; M 108, M 110 111, 112, 115, 116
	8/70 -			
-	113 415 651 A	Steering wheel ..... from Chassis No. 116 000 001 up to 116 1021 300 466 silver beige	1	M 1, M 11, M 110: 111, 112, 115, 116
	8/65 - 7/66			
66	311 415 651 A	Steering wheel ..... up to Chassis No. 110 3100 000 model 141-144: from Chassis No. 4 010 995 up to 5 677 118 use 113 951 531 E model 111, 112, 115, 116: from Chassis No. 117 000 001 use: 113 415 669 B Emblem 113 951 531 E Horn ring 113 951 547 Insulating bush 113 951 555 A Spring 113 951 563 Contact washer 395 ice blue - 58, 62, 74, 77	1 1 3 3 1	141-144
	8/61 - 7/63			
	8/61 - 7/65	○ 466 silver beige / superseded by: 311 415 651 D [043]	1	113, 114, 117, 118, 141-144, 151, 152
	8/65 - 7/66	○ 043 grey black / superseded by: 311 415 651 D [043]	1	113, 114, 117, 118, 141-144, 151, 152
	8/65 - 7/66	651 pigalle - 79	1	141-144
	8/65 - 7/66	671 Teak - 66	1	141-144
	8/66 - 7/70	○ 043 grey black / superseded by: 311 415 651 D [043]	1	
-	311 415 651 D	Steering wheel ..... from Chassis No. 111 2000 001 up to 111 3200 000 043 grey black	1	141-144; M 1
	8/70 -			



Key No.	Part No.	Description	Quantity	Type and model
-	113 415 651 H 8/71 -	Steering wheel ..... from Chassis No. 112 2000 001 043 grey-black	1	141-144; M 1, M 108, M 110
-	111 415 655 A 8/65 - 7/66	Steering wheel ..... from Chassis No. 116 000 001 up to 116 1021 300 466 silver beige	1	111, 112, 115, 116
-	111 415 657	Self-cancelling ring - Flashing indicator switch ... from Chassis No. 116 000 001 up to 116 1021 300	1	111, 112, 115, 116
-	113 415 660 A	Cancelling ring with contact ring ..... for turn signal switch from Chassis No. 112 2000 001	1	141-144; M 1, M 108, M 110
-	311 415 660	Cancelling ring with contact ring ..... for turn signal switch from Chassis No. 111 2000 001 up to 111 3200 000 from Chassis No. 112 2000 001	1	111, 112, 115, 116, 141-144; M 1; M 108, M 110 111, 112, 115, 116
-	113 415 661 B	Self-cancelling ring - Flashing indicator switch ... up to Chassis No. 116 1021 300 from Chassis No. 117 000 001 up to 117 999 000	1 1	113, 114, 117, 118, 141-144, 151, 152
67	113 415 661 C	Self-cancelling ring - Flashing indicator switch .. from Chassis No. 118 000 001	1	
68	N 10 803 2	Screw, fillister head M 3.5×10 ..... up to Chassis No. 116 1021 300 from Chassis No. 117 000 001	3 3	113, 114, 117, 118, 141-144, 151, 152;
69	N 12 131 2	Shake-proof washer J 3.7 ..... up to Chassis No. 116 1021 300 from Chassis No. 117 000 001	3 3	113, 114, 117, 118, 141-144, 151, 152
-	N 10 901 2	Screw, countersunk head AM 3×8 ..... from Chassis No. 117 000 001	2	111, 112, 115, 116
70	N 12 239 1	Spring washer B 18 ..... up to Chassis No. 116 1021 300 from Chassis No. 117 000 001	1 1	113, 114, 117, 118, 141-144, 151, 152
71	N 11 165 3	Nut, hex. M 18×1.5 ..... from Chassis No. 117 000 001 from Chassis No. 117 000 001	1 1	113, 114, 117, 118, 141-144, 151, 152
72	311 415 535	Retaining plug - Steering column ..... from Chassis No. 118 000 001	1	

Key No.	Part No.	Description	Quantity	Type and model
73	113 415 669 B	Emblem – Horn ring .....	1	113, 114, 117, 118, 151, 152
		up to Chassis No. 110 3100 000	1	141-144
		up to Chassis No. 111 3200 000	1	M 1
		from Chassis No. 111 2000 001 up to 111 3200 000	1	
-	113 415 669 E	Cap – Steering wheel .....	1	141-144; M 1, M 108, M 110
		from Chassis No. 112 2000 001		
-	211 415 669	Emblem – Horn ring .....	1	111, 112, 115, 116; M 108, M 110
		from Chassis No. 117 000 001 up to 111 3200 000	1	111, 112, 115, 116
		from Chassis No. 112 2000 001	1	
-	113 415 673 A	Spring – Cover .....	4	141-144; M 1, M 108, M 110
		from Chassis No. 112 2000 001		
-	111 415 691	Nut – Steering wheel .....	1	111, 112, 115, 116
		up to Chassis No. 116 1021 300		
-	113 415 791 A	Trim – Steering wheel .....	1	141-144; M 1, M 108, M 110
		from Chassis No. 112 2000 001		
-	113 857 113	Clamping plate .....	4	141-144; M 1, M 108, M 110
		from Chassis No. 112 2000 001		
-	113 415 801	Tie rod, left, adjustable .....	1	113, 117, 141, 143, 151
		up to Chassis No. 115 999 000		
-	114 415 801 C	Tie rod, left, adjustable .....	1	114, 118, 142, 144, 152
		up to Chassis No. 115 999 000		
-	131 415 801 B	Tie rod, left .....	1	111, 113, 115, 117, 141, 143, 151
		from Chassis No. 116 000 001 up to 118 857 239		
74	131 415 801 F	Tie rod, left .....	1	111, 113, 115, 117, 141, 143, 151
		from Chassis No. 118 857 240		
-	132 415 801 C	Tie rod, left .....	1	112, 114, 116, 118, 142, 144, 152
		from Chassis No. 116 000 001 up to 118 857 239		

Key No.	Part No.	Description	Quantity	Type and model
-	132 415 801 F	Tie rod, left ..... from Chassis No. 118 857 240	1	112, 114, 116, 118, 142, 144, 152
-	113 415 802 B	Tie rod, right, adjustable ..... up to Chassis No. 115 999 000	1	113, 117, 141, 143, 151
-	131 415 802 C	Tie rod, right ..... from Chassis No. 116 000 001 up to 118 857 239	1	111, 113, 115, 117, 141, 143, 151
75	131 415 802 E	Tie rod, right ..... from Chassis No. 118 857 240	1	111, 113, 115, 117, 141, 143, 151
-	114 415 802	Tie rod, right, adjustable ..... up to Chassis No. 115 999 000	1	114, 118, 142, 144, 152
-	132 415 802 A	Tie rod, right ..... from Chassis No. 116 000 001 up to 118 857 239	1	112, 114, 116, 118, 142, 144, 152
-	132 415 802 E	Tie rod, right ..... from Chassis No. 118 857 240	1	112, 114, 116, 118, 142, 144, 152
-	131 415 811	Tie rod end, straight, left-hand thread ..... up to Chassis No. 118 857 239	1	
76	311 415 811 C	Tie rod end, straight, left-hand thread ..... from Chassis No. 118 857 240	1	
-	131 415 812	Tie rod end, straight, left-hand thread ..... up to Chassis No. 118 857 239	1	
77	311 415 812 C	Tie rod end, straight, right-hand thread ..... from Chassis No. 118 857 240	1	
-	113 415 813	Tie rod end for steering damper ..... with left-hand thread up to Chassis No. 115 999 000	1	
-	113 415 813 D	Tie rod end for steering damper with left-hand ... thread (use for 131 415 802 C and 132 415 801 C only) from Chassis No. 116 000 001 up to 118 857 239	1	
78	131 415 813 E	Tie rod end for steering damper ..... with left-hand thread from Chassis No. 118 857 240	1	

Key No.	Part No.	Description	Quantity	Type and model
-	113 415 821 ✓	Tie rod end, angled, right-hand thread ..... up to Chassis No. 118 857 239	1	
79	131 415 821 A	Tie rod end, angled, right-hand thread ..... from Chassis No. 118 857 240	1	
-	N 11 210 1	Nut, slotted M 10×1 ..... up to Chassis No. 118 857 239	4	
80	N 11 212 2	Nut, slotted M 12×1.5 ..... from Chassis No. 118 857 240	4	
-	N 12 522 1	Cotter pin 2×22 ..... up to Chassis No. 118 857 239	4	
81	N 12 532 1	Cotter pin 3×25 ..... from Chassis No. 118 857 239	4	
82	113 415 835	Dust seal – Tie rod end .....	4	
83	111 415 837	Retaining ring 27 mm dia. – Dust seal .....	4	
-	113 415 837	Retaining ring 8.2 mm dia. – Dust seal .....	4	
84	111 415 841 A	Retaining clip, 18 mm dia. .... from Chassis No. 116 000 001 up to 117 112 756 from Chassis No. 117 112 757	4 3	
85	N 10 171 1	Bolt, hex. M 8×1×30 ..... from Chassis No. 116 000 001 up to 117 112 756 from Chassis No. 117 112 757	4 3	
	N 12 008 2	Spring washer B 8 ..... from Chassis No. 116 000 001 up to 117 112 756 from Chassis No. 117 112 757	4 3	
17	N 11 018 2	Nut, hex. M 8×1 ..... from Chassis No. 116 000 001 up to 117 112 756 from Chassis No. 117 112 757	4 3	
-	141 415 851 B	Lock plate ..... up to Chassis No. 115 999 000	4	
88	141 415 855 A	Taper ring ..... up to Chassis No. 115 999 000 from Chassis No. 116 000 001	4 1	

Key No.	Part No.	Description	Quantity	Type and model
89	N 11 163 3	Nut, hex. M 14×1.5 ..... up to Chassis No. 115 999 000	2	
-	N 11 163 2	Nut, hex. M 14×1.5 left-hand thread ..... up to Chassis No. 115 999 000	2	

STEERING DAMPER

90	113 425 021	Steering damper ..... up to Chassis No. 115 999 000 from Chassis No. 116 000 001	1 1	114, 118, 141-144, 152
-	113 425 021 A	Steering damper ..... up to Chassis No. 115 999 000	1	113, 117, 151
-	N 11 134 2	Nut, hex. M 10 ..... up to Chassis No. 115 999 000	2	
91	131 405 323 <i>411.349-149</i>	Nut, hex. M 10×1 self locking ..... from Chassis No. 116 000 001	1	
92	113 415 907 C	Grommet - Tie rod end and steering damper .... Stabilus and Hemscheidt	2	
93	211 415 907 C	Rubber grommet - Steering damper ..... 1		
94	211 415 909	Bush - Grommet ..... 2		
95	113 415 949	Lock plate - Steering damper ..... 1		
96	N 10 440 1	Bolt, hex. head M 10×40 ..... 1		

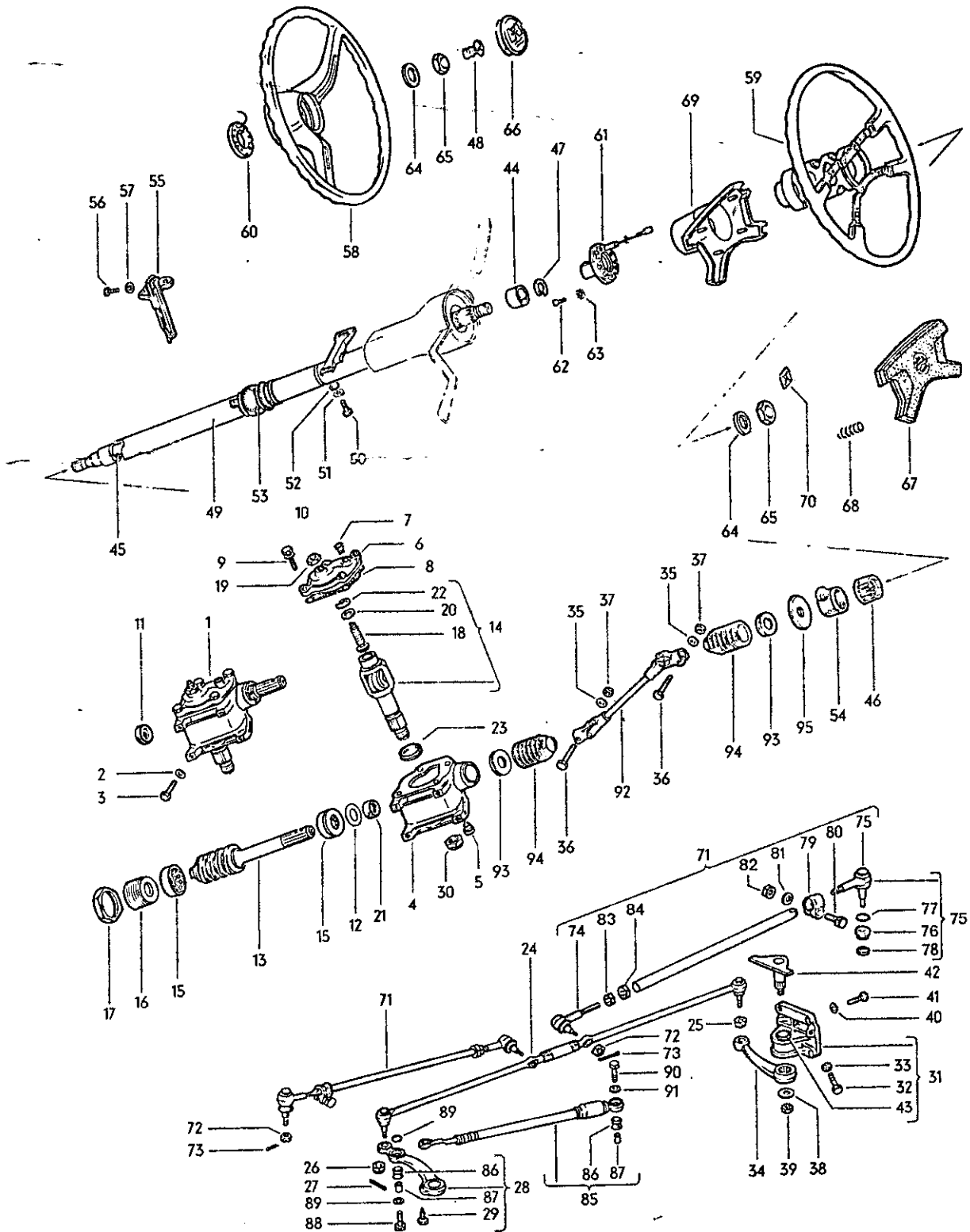

Key No.	Part No.	Description	Quantity	Type and model
<b>STEERING</b> <b>(Roller Type Steering)</b> from Chassis No. 111 2000 001				113, 114, 117, 118, 151, 152
(1)	113 415 061 B <i>SS BY</i>	Steering gear assy. .... up to Chassis No. February 1972	1	113, 117, 151
1	113 415 061 E	Steering gear assy. .... from Chassis No. March 1972	1	113, 117, 151
(1)	114 415 061 A	Steering gear assy. .... up to Chassis No. February 1972	1	114, 118, 152
(1)	114 415 061 C	Steering gear assy. .... from Chassis No. March 1972	1	114, 118, 152
2	111 899 121 B	Washer .....	3	
3	N 10 470 1	Bolt, hex. head M 10×70 .....	3	
4	113 415 105 A	Case- Steering gear .....	1	
5	113 415 113	Stop plug for fixing the steering .....	1	
		(required for adjusting)		
6	113 415 129 A	Cover - Steering gear case .....	1	
7	311 415 133	Retaining plug - Steering gear case cover .....	2	
8	113 415 135	Gasket - Steering gear case cover .....	1	
9	N 10 242 5	Bolt, hex. head M 8×25 .....	4	
10	N 12 228 2	Spring washer B 8 .....	4	
11	114 415 137	Cap - Steering gear case .....	1	114, 118, 152
12	113 415 193	Shim 0.20 mm - Steering worm .....	x	
(12)	113 415 194	Shim 0.25 mm - Steering worm .....	x	
(12)	113 415 195	Shim 0.30 mm - Steering worm .....	x	
(12)	113 415 196	Shim 0.35 mm - Steering worm .....	x	
(12)	113 415 197	Shim 0.40 mm - Steering worm .....	x	
(12)	113 415 198	Shim 0.45 mm - Steering worm .....	x	

Key No.	Part No.	Description	Quantity	Type and model
(12)	113 415 199	Shim 0.50 mm – Steering worm .....	x	
13	113 415 205 A	Steering worm .....	1	113, 117, 151
(13)	114 415 205 A	Steering worm .....	1	114, 118, 152
(14)	113 415 217 A	Steering roller shaft .....	1	113, 117, 151
		up to Chassis No. February 1972		
14	113 415 217 C	Steering roller shaft .....	1	113, 117, 151
		from Chassis No. March 1972		
(14)	114 415 217 A	Steering roller shaft .....	1	114, 118, 152
		up to Chassis No. February 1972		
(14)	114 415 217 C	Steering roller shaft .....	1	114, 118, 152
		from Chassis No. March 1972		
15	113 415 227	Ball bearing – Steering worm .....	2	
16	113 415 251	Adjusting screw – Steering worm .....	1	113, 117, 151
(16)	114 415 251	Adjusting screw – Steering worm .....	1	114, 118, 152
17	113 415 261	Lock nut – Adjusting screw .....	1	
18	113 415 263	Adjusting screw – Steering roller shaft .....	1	
19	N 11 157 1	Nut, hex. M 10×1 .....	1	
20	311 415 265	Shim 2.00 mm – Steering roller shaft .....	x	
(20)	311 415 266	Shim 2.05 mm – Steering roller shaft .....	x	
(20)	311 415 267	Shim 2.10 mm – Steering roller shaft .....	x	
(20)	311 415 268	Shim 2.15 mm – Steering roller shaft .....	x	
(20)	311 415 269	Shim 2.20 mm – Steering roller shaft .....	x	
(20)	311 415 270	Shim 2.25 mm – Steering roller shaft .....	x	
21	113 415 277	Seal – Steering worm .....	1	
22	113 415 283	Lockring – Adjusting screw .....	1	
23	113 415 297	Seal A 28×40×7 – Steering roller shaft .....	1	
24	113 415 303	Tie rod, center .....	1	
(25)	113 415 339	Dust seal – Tie rod end, center (Lemförder) .....	2	



Key No.	Part No.	Description	Quantity	Type and model
25	411 417 465 A	Dust seal – Tie rod end, center (Ehrenreich) . . . . .	2	
26	N 11 212 2	Nut, slotted M 12×1.5 . . . . .	2	
27	N 12 532 1	Cotter pin 3×25 . . . . .	2	
28	113 415 365 A	Steering drop arm . . . . . up to Chassis No. January 1972	1	113, 117, 151
(28)	113 415 365 B	Steering drop arm . . . . . from Chassis No. February 1972	1	113, 117, 151
(28)	114 415 365 A	Steering drop arm . . . . . up to Chassis No. January 1972	1	114, 118, 152
(28)	114 415 365 B	Steering drop arm . . . . . from Chassis No. February 1972	1	114, 118, 152
29	113 415 375	Fixing screw – Steering gear . . . . . (required for adjusting)	1	
30	411 417 239	Lock nut – Drop arm . . . . .	1	
(32)	113 415 389	Bolt, hex. head M 12×1.5×45 . . . . . from Chassis No. February 1972	1	
(32)	113 415 390	Bolt, hex. head M 12×1.5×48 . . . . . from Chassis No. February 1972	1	
31	113 415 393 B	Bracket – Steering idler arm . . . . . up to Chassis No. January 1972	1	
(31)	113 415 393 C	Bracket – Steering idler arm . . . . . from Chassis No. February 1972 up to April 1972	1	
(31)	113 415 393 D	Bracket – Steering idler arm . . . . . from Chassis No. May 1972	1	
32	N 10 242 5	Bolt, hex. head M 8×25 . . . . . up to Chassis No. January 1972	2	
33	N 11 008 8	Nut, hex. M 8 . . . . . up to Chassis No. January 1972	2	
(33)	N 11 135 1	Nut, hex. M 12×1.5 . . . . . from Chassis No. February 1972	2	



Key No.	Part No.	Description	Quantity	Type and model
34	113 415 399 A	Steering idler arm – Tie rod, center ..... up to Chassis No. January 1972	1	113, 117, 151
(34)	113 415 399 B	Steering idler arm – Tie rod, center ..... from Chassis No. February 1972	1	113, 117, 151
(34)	114 415 399 A	Steering idler arm – Tie rod, center ..... up to Chassis No. January 1972	1	114, 118, 152
(34)	114 415 399 B	Steering idler arm – Tie rod, center ..... from Chassis No. February 1972	1	114, 118, 152
35	N 12 241 2	Lock washer B 8×15 .....	2	
36	111 415 421 A	Bolt, hex. head M 8×37 – Steering coupling ....	2	
37	113 415 431 A	Nut, hex. M 8 self-locking .....	2	
38	113 499 131	Washer – Pin .....	1	
39	411 412 149	Nut, hex. M 14×1.5 self-locking .....	1	
(39)	411 513 481	Nut, hex. M 12×1.5 self-locking .....	1	
40	111 899 121 B	Washer .....	3	
41	N 10 470 1	Bolt, hex. head M 10×70 .....	3	
42	113 415 435 B	Pin – Steering idler arm .....	1	
-	411 417 317	Fitted bolt – Steering idler arm .....	1	
43	113 415 441	Bonded rubber mounting – Steering idler arm ...	1	
(43)	411 417 325	Bonded rubber mounting – Steering idler arm ...	1	

Key No.	Part No.	Description	Quantity	Type and model
61	113 415 660 A	Cancelling ring with contact ring ..... for turn signal switch from Chassis No. 112 2000 001	1	
62	N 10 803 2	Screw, fillister head M 3.5×10 .....	3	
63	N 12 131 2	Shake-proof washer J 3.7 .....	3	
64	N 12 239 1	Spring washer B 18 .....	1	
65	N 11 165 3	Nut, hex. M 18×1.5 .....	1	
66	113 415 669 B	Emblem – Horn ring ..... up to Chassis No. 111 3200 000	1	
67	113 415 669 E	Cap – Steering wheel ..... from Chassis No. 112 2000 001	1	
68	113 415 673 A	Spring – Cover ..... from Chassis No. 112 2000 001	4	
69	113 415 791 A	Trim – Steering wheel ..... from Chassis No. 112 2000 001	1	
70	113 857 113	Clamping plate ..... from Chassis No. 112 2000 001	4	
71	113 415 801 F	Tie rod, side .....	2	
72	N 11 212 2	Nut, slotted M 12×1.5 .....	4	
73	N 12 532 1	Cotter pin 3×25 .....	4	
74	113 415 811 C	Tie rod end, straight, left-hand thread .....	2	
75	113 415 812 C	Tie rod end, straight, right-hand thread .....	2	
76	113 415 835	Dust seal – Tie rod end .....	4	
77	111 415 837	Retaining ring 27 mm dia., upper – Dust seal ....	6	

Key No.	Part No.	Description	Quantity	Type and model
78	311 405 387 A	Retaining ring 13.8 mm dia., lower – Dust seal ...	4	
79	111 415 841 A	Retaining clip, 18 mm dia. – Tie rod .....	2	
80	N 10 171 1	Bolt, hex. head M 8×1×32 .....	2	
81	N 12 008 2	Spring washer B 8 .....	2	
82	N 11 018 2	Nut, hex. M 8×1 .....	2	
83	N 11 163 2	Nut, hex. M 14×1.5, left-hand thread .....	2	
84	141 415 855 A	Taper ring .....	2	

STEERING DAMPER

85	113 425 021 C	Steering damper .....	1	
86	143 415 907 C	Rubber grommet – Steering damper .....	2	
87	SS 113 425 021 C <del>311 415 909</del>	Bush – Grommet .....	2	
88	N 10 440 1	Bolt, hex. head M 10×40 .....	1	
89	N 12 111 1	Shake-proof washer J 10.5 .....	2	
90	N 10 020 1	Bolt, hex. head M 10×38 .....	1	
91	N 12 111 1	Shake-proof washer J 10.5 .....	1	
92	113 415 951	Universal joint shaft between steering gear ..... and steering column	1	
93	113 415 977	Ring – Dust sleeve .....	1	
94	113 415 979 B	Dust sleeve – Universal joint shaft .....	2	
95	113 415 991 A	Support ring – Steering column .....	1	

Part No.	Description	Quantity
<b>REPAIR KITS</b>		
<b>111 498 001 A</b>	<b>1 set of additional front axle supports</b>	
	comprising:	
	Support tube .....	2
	Bracket, front .....	2
	Distance shim 4 mm – Support .....	4
	Distance shim 2 mm – Support .....	4
	Packing – Support tube .....	2
N 10 455 1	Bolt, hex. head BM 10×55 .....	4
N 10 033 1	Bolt, hex. head BM 10×82 .....	4
N 11 010 4	Nut, hex. M 10 .....	4
N 12 011 2	Spring washer A 10 .....	4
<b>111 498 021</b>	<b>1 king pin with bushes and shims</b>	
	up to Chassis No. 115 999 000	
	comprising:	
111 405 391	Bush – King pin .....	2
111 405 411	King pin .....	1
111 405 501	Thrust washer (fiber) – King pin .....	1
111 405 511	Cover – King pin thrust washer .....	1
<b>111 498 051</b>	<b>2 torsion arm link pins with bushes and shims</b>	
	up to Chassis No. 2 921 551	
	comprising:	
111 405 395 A	Bush – Torsion arm link pin .....	2
111 405 521	Pin – Torsion arm link .....	2
111 405 527	Shim – Torsion arm link pin .....	20
111 405 681	Lock plate .....	1
N 10 445 1	Bolt, hex. head M 10×45 .....	2
N 11 010 4	Nut, hex. M 10 .....	2
N 12 011 2	Lock washer A 10 .....	2
<b>111 498 051 A</b>	<b>2 torsion arm link pins with bushes, shims and dust excluders</b>	
	from Chassis No. 2 921 552 up to 115 999 000	
	comprising:	
111 405 395 A	Bush – Torsion arm link pin .....	2
111 405 517	Dust excluder .....	2
111 405 521	Pin – Torsion arm link .....	2
111 405 527	Shim – Torsion arm link pin .....	16
111 405 537	Retainer – Dust excluder .....	2
111 405 681	Lock washer .....	1
N 10 445 1	Bolt nut hex. M 10×45 .....	2
N 11 010 4	Nut hex. M 10 .....	2
N 12 011 2	Spring ring A 10 .....	2

Part No.	Description	Quantity
111 498 071	<b>Bearing set for 1 front wheel</b> up to Chassis No. 115 999 000 comprising:	
111 405 625 A	Ball bearing – Front wheel (inner) .....	1
111 405 631 B	Spacer .....	1
111 405 641 A	Oil seal .....	1
111 405 645 A	Ball bearing – Front wheel (outer) .....	1
111 405 661	Thrust washer – Front wheel bearing .....	1
111 405 681	Lock plate .....	1
111 498 071 A	* <b>Bearing set for 1 front wheel</b> from Chassis No. 116 000 001 up to 116 1021 300: 111-118, 141-144, 151, 152 from Chassis No. 117 000 001 up to 118 857 239: 111, 112, 115, 116; M 87, M 88, M 129, M 137, M 139 comprising:	
311 405 625	Ball bearing – Front wheel (inner) .....	1
131 405 641 A	Oil seal .....	1
311 405 645	Ball bearing – Front wheel (outer) .....	1
311 405 661	Thrust washer .....	1
111 498 071 B	* <b>Bearing set for 1 front wheel</b> from Chassis No. 118 857 240: 111, 112, 115, 116; M 87, M 88, M 129, M 137, M 139 comprising:	
311 405 625 A	Ball bearing – Front wheel (inner) .....	1
111 405 641 B	Oil seal .....	1
311 405 645	Ball bearing – Front wheel (outer) .....	1
311 405 661	Thrust washer .....	1
311 498 071 A	<b>Bearing set for 1 front wheel</b> from Chassis No. 117 000 001 up to 118 857 239: 113, 114, 117, 118, 141-144, 151, 152 comprising:	
311 405 625	Ball bearing – Front wheel (inner) .....	1
311 405 641 A	Oil seal .....	1
311 405 645	Ball bearing – Front wheel (outer) .....	1
311 405 661	Thrust washer .....	1

Part No.	Description	Quantity
<b>311 498 071 B</b>	<b>Bearing set for 1 front wheel</b> from Chassis No. 118 857 240: 113, 114, 117, 118, 141-144, 151, 152; M 80	
	comprising:	
311 405 625 A	Ball bearing, inner – Front wheel .....	1
311 405 641 B	Oil seal .....	1
311 405 645	Ball bearing, outer – Front wheel .....	1
311 405 661	Thrust washer .....	1
<b>111 498 101</b>	<b>1 set of stabilizer mounting parts for one side</b> up to Chassis No. 115 999 000	
	comprising:	
141 411 313	Rubber cushion, large .....	1
141 411 317	Rubber cushion, small .....	1
141 411 323	Spring retaining clip, large .....	1
141 411 327	Spring retaining clip, small .....	1
141 411 333	Spring clip, large .....	1
141 411 337	Spring clip, small .....	1
<b>111 498 101 A</b>	<b>1 set of stabilizer mounting parts for one side</b> from Chassis No. 116 000 001 up to 110 3100 000: 111-118, 141-144, 151, 152 from Chassis No. 111 2000 001: 111, 112, 115, 116, 141-144; M 1	
	comprising:	
	Rubber cushion, large .....	1
	Rubber cushion, small .....	1
141 411 323	Spring retaining clip, large .....	1
141 411 327	Spring retaining clip, small .....	1
	Spring clip, large .....	1
	Spring clip, small .....	1
<b>111 498 121</b>	<b>1 set of grommets with bushes for adjustable shock absorbers 211 413 031 B</b>	
	comprising:	
	Grommet .....	2
	Bush – Rubber grommet .....	2



Part No.	Description	Quantity
111 498 151	<b>Repair kit for steering gear (Sector Type Steering)</b> up to Chassis No. 115 999 000 comprising:	
111 415 115	Cap - Steering gear case .....	1
111 415 135	Gasket - Steering gear case cover .....	1
111 415 159	Lock plate - Mounting clamp .....	2
111 415 285 A	Sealing washer - Adjusting sleeve .....	1
111 415 385	Lock plate - Steering drop arm .....	1
113 415 431 A	Nut, hex. M 8 self locking .....	1
N 12 241 2	Spring washer B 8x15 DIN 137 galvanized .....	1
111 415 543	Lock plate .....	1
N 14 902 1	Sealing washer B 28x40 - Sector shaft .....	1