

# MAIN GROUP

7

## FRAME HAND LEVER SYSTEM PEDAL CLUSTER

	Illustration
01 Frame	36
07 Bumpers	A 36
11 Hand lever system	37 + A 37
13 Hand lever system (Automatic)	A 37
21 Pedal cluster	38 + A 38 + B 38
98 Repair kits	

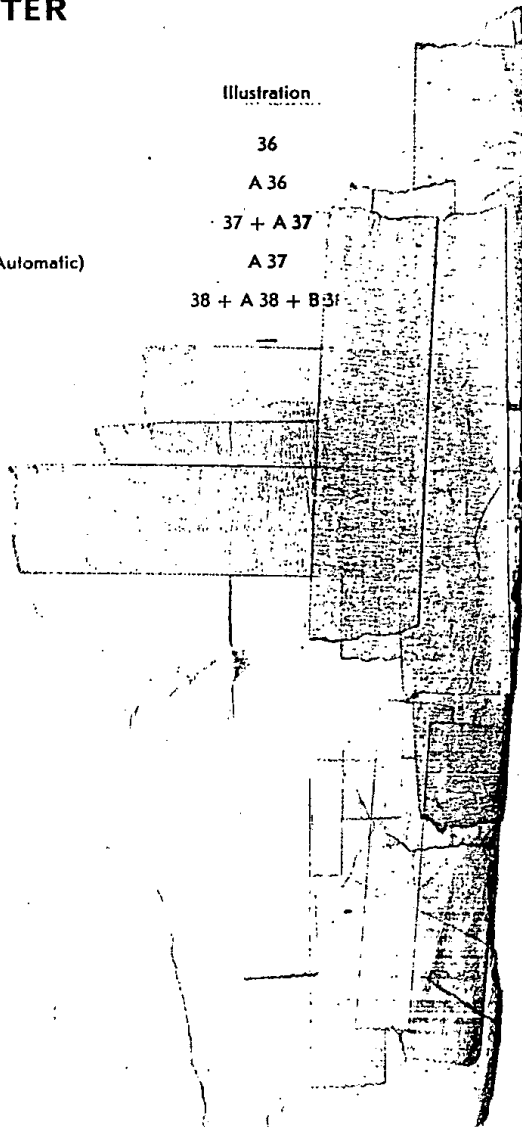

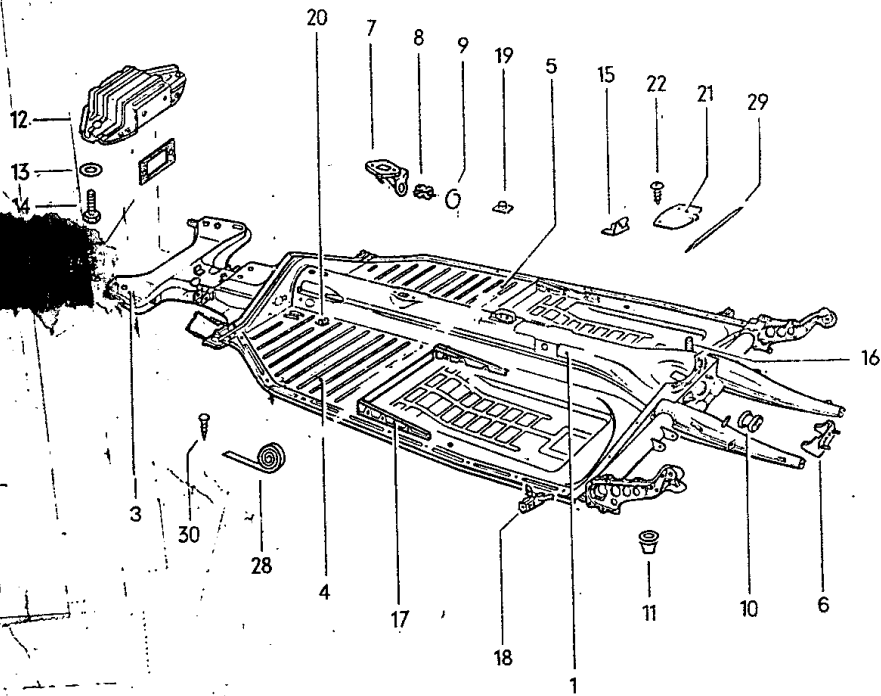
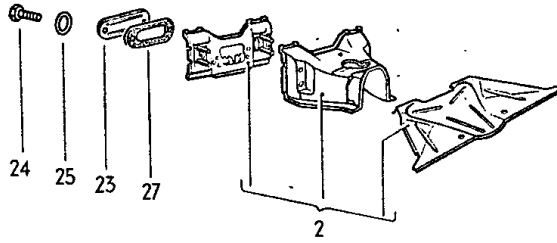

Key No.	Part No.	Description	Quantity	Type and model
<b>FRAME</b>				
(1)	111 700 021	Frame without sound absorbers ..... up to Chassis No. 1 - 397 022	1	111, 112, 115, 116
(1)	111 700 021 A	Frame without sound absorbers ..... from Chassis No. 1 - 397 023 up to 1 - 929 745	1	111, 112, 115, 116
(1)	111 700 021 G	Frame without sound absorbers ..... from Chassis No. 1 - 929 746 up to 3 192 506	1	111, 115
(1)	111 700 021 P	Frame without sound absorbers ..... from Chassis No. 3 192 507 up to 4 630 937	1	111, 115
(1)	111 700 021 AC	Frame without sound absorbers ..... from Chassis No. 116 000 001 up to 117 999 000 (from Chassis No. 116 000 001 up to 116 851 649 use 113 721 231 B)	1	111, 115
(1)	111 700 021 AJ	Frame without sound absorbers ..... from Chassis No. 118 000 001 up to 110 3100 000	1	111, 115; M 110
(1)	111 700 021 BA *	Frame without sound absorbers ..... from Chassis No. 111 2000 001 up to 111 3200 000	1	111, 115; M 108; M 110
(1)	112 700 021 F	Frame without sound absorbers ..... from Chassis No. 3 192 507 up to 4 630 937	1	112, 116
(1)	113 700 021 E	Frame without sound absorbers ..... from Chassis No. 1 - 397 023 up to 3 192 506	1	113, 117, 151
(1)	113 700 021 M *	Frame with sound absorbers ..... from Chassis No. 3 192 507 up to 115 999 000	1	113, 117, 151; M 110
(1)	113 700 021 R *	Frame with sound absorbers ..... from Chassis No. 116 000 001 up to 117 999 000 (from Chassis No. 116 000 001 up to 116 851 649 use 113 721 231 B)	1	113, 117, 151; M 110
(1)	113 700 021 S *	Frame with sound absorbers ..... from Chassis No. 119 000 001 up to 110 3100 000	1	M 4: 113, 117, 151
(1)	113 700 021 AH	Frame with sound absorbers ..... from Chassis No. 111 2000 001 up to 111 3200 000	1	113, 117, 151
(1)	113 700 021 AJ	Frame with sound absorbers ..... from Chassis No. 118 000 001 up to 110 3100 000	1	113, 117, 151



Key No.	Part No.	Description	Quantity	Type and model
(1)	113 700 021 AK	Frame with sound absorbers from Chassis No. 118 071 440 up to 110 3100 000 from Chassis No. 110 2000 001 up to 110 3100 000	1 1	M 9: 113, 117, 151 M 9: 111, 115
(1)	113 700 021 AQ	Frame with sound absorbers from Chassis No. 111 2000 001 up to 111 3200 000	1	M 9: 113, 117, 151
(1)	113 700 021 BA	Frame with sound absorbers from Chassis No. 111 2000 001 up to 111 3200 000	1	M 1: 113, 117
(1)	113 700 021 BB *	Frame with sound absorbers from Chassis No. 111 2000 001 up to 111 3200 000	1	M 1/M 4: 113, 117
(1)	113 700 021 BC	Frame with sound absorbers from Chassis No. 111 2000 001 up to 111 3200 000	1	M 9: 111, 115; M 1/M 9: 113, 117
1	113 700 021 BF	Frame with sound absorbers from Chassis No. 112 2000 001	1	113, 117, 151; M 9
(1)	113 700 021 BG	Frame with sound absorbers from Chassis No. 112 2000 001	1	111, 115; M 1: 113, 117; M 110
(1)	113 700 021 BH	Frame with sound absorbers from Chassis No. 112 2000 001	1	M 9: 111, 115; M 1/M 4: 113, 117; M 108, M 1/M, 9: 113, 117
(1)	114 700 021 L	Frame with sound absorbers from Chassis No. 3 192 507 up to 115 999 000 from Chassis No. 4 630 938 up to 115 999 000	1 1	114, 118, 152 112, 116
(1)	114 700 021 Q	Frame with sound absorbers from Chassis No. 116 000 001 up to 117 999 000 from Chassis No. 116 000 001 up to 116 851 649 the following parts are additionally required: 312 721 121 B Mounting tube - Pedal cluster 112 721 141 Pedal - Brake 132 721 163 Return spring - Brake pedal 311 721 173 A Rubber pad - Brake and clutch pedals 113 721 205 L Push rod - Master cylinder 312 721 241 Bracket - Pedal cluster 312 721 315 A Pedal - Clutch 114 721 539 A Accelerator pedal shaft from Chassis No. 116 000 001 up to 116 460 613 the following parts are additionally required: 112 721 505 A Pedal - Accelerator 311 721 519 Lock washer - Rolle 311 721 521 Roller - Accelerator pedal 114 721 555 A Cable - Accelerator 311 721 619 Return spring - Accelerator pedal N 11 557 2 Washer A 6.4	1 1 1 2 1	112, 114, 116, 118, 152
(1)	114 700 021 AH	Frame with sound absorbers from Chassis No. 111 2000 001 up to 111 3200 000	1	114, 118, 152

Key No.	Part No.	Description	Quantity	Type and model
(1)	114 700 021 AJ	Frame with sound absorbers ..... from Chassis No. 118 000 001 up to 110 3100 000	1	112, 114, 116, 118, 152
(1)	114 700 021 AK	Frame with sound absorbers ..... from Chassis No. 110 2000 001 up to 110 3100 000	1	M 9: 112, 116
		up to Chassis No. 110 3100 000	1	M 9: 114, 118, 152
(1)	114 700 021 AQ	Frame with sound absorbers ..... from Chassis No. 111 2000 001 up to 111 3200 000	1	M 9: 114, 118, 152
(1)	114 700 021 BA	Frame with sound absorbers ..... from Chassis No. 111 2000 001 up to 111 3200 000	1	112, 116; M 1: 114, 118
(1)	114 700 021 BC	Frame with sound absorbers ..... from Chassis No. 111 2000 001 up to 111 3200 000	1	M 9: 112, 116; M 1/M 9: 114, 118
(1)	114 700 021 BF	Frame with sound absorbers ..... from Chassis No. 112 2000 001	1	114, 118, 152; M 9
(1)	114 700 021 BG	Frame with sound absorbers ..... from Chassis No. 112 2000 001	1	112, 116; M 1: 114, 118
(1)	114 700 021 BH	Frame with sound absorbers ..... from Chassis No. 112 2000 001	1	M 9; 112, 116; M 1/M 4: 114, 118; M 1/M 9: 114, 118
(1)	111 700 025 M	Frame without sound absorbers ..... from Chassis No. 4 630 938 up to 115 999 000	1	111, 115; M 110
(1)	111 700 025 R	Frame without sound absorbers ..... from Chassis No. 116 000 001 up to 116 851 649	1	111, 115
(2)	113 701 037 C	Frame head ..... up to Chassis No. 115 999 000	1	
2	131 701 037 A	Frame head ..... from Chassis No. 116 000 001 up to 110 3100 000 from Chassis No. 111 2000 001 up to 111 3200 000	1 1	111, 112, 115, 116; M 1
3	113 701 037 D	Frame head ..... from Chassis No. 111 2000 001	1	113, 114, 117, 118, 151, 152
(2)	113 701 037 F	Frame head ..... from Chassis No. 112 2000 001	1	111, 112, 115, 116; M 1
(4)	112 701 060 B	Floor plate, right ..... up to Chassis No. 1 - 929 745	1	111, 112, 115, 116
(4)	111 701 061 K	Floor plate, left ..... up to Chassis No. 1 600 439 from Chassis No. 1 600 440 up to 115 999 000 (For Types 113, 114, 117, 118, 151, 152 two of 113 701 425 should also be used up to Chassis No. 1 - 929 745 and 113 701 425/421 D from Chassis No. 1 - 929 746)	1 1	111, 112, 115, 116



Key No.	Part No.	Description	Quantity	Type and model
(4)	111 701 061 M	Floor plate, left ..... from Chassis No. 1 600 440 up to 115 999 000 from Chassis No. 116 000 001 up to 110 3100 000 (from Chassis No. 1 600 440 up to 116 851 649 for Types 113, 117, 151 one of 113 721 231 B should also be used)	1 1	113, 114, 117, 118, 151, 152
4	111 701 061 N	Floor plate, left ..... from Chassis No. 111 2000 001	1	111-118, 151, 152
(5)	112 701 062 H	Floor plate, right ..... up to Chassis No. 1 - 929 745 from Chassis No. 1 - 929 746 up to 1 600 439 from Chassis No. 1 600 440 up to 115 999 000 (For Types 113, 114, 117, 118, 151, 152 two of 113 701 425 should also be used up to Chassis No. 1 - 929 745 and 113 701 421 D from Chassis No. 1 - 929 746)	1 1 1	111,112,114,115,116,118,152 111, 112, 115, 116
(5)	112 701 062 K	Floor plate, right ..... (use 114 721 231 A/239 A for Type 114, 118, 152) from Chassis No. 1 - 929 746 up to 1 600 439 from Chassis No. 1 600 440 up to 115 999 000 from Chassis No. 116 000 001 up to 110 3100 000 (from Chassis No. 1 600 440 up to 116 851 649 for Types 114, 118, 152 114 721 231 A and 114 721 329 A should also be used)	1 1 1	113, 117, 151 113, 114, 117, 118, 151, 152
5	112 701 062 N	Floor plate, right ..... from Chassis No. 111 2000 001	1	111-118, 151, 152
6	113 701 173	Mounting plate - Transmission to frame ..... from Chassis No. 118 000 001	1	
(6)	111 701 173 C	Mounting plate - Transmission to frame ..... from Chassis No. 3 192 507 up to 117 999 000 (use 311 301 265 B up to Chassis No. 115 999 000)	1	
-	N 14 420 4	Stud AM 10 B×32 ..... up to Chassis No. 1 600 439	2	
-	111 701 211	Extension - Hand brake cable conduit ..... (see Technical Bulletin R 1) up to Chassis No. 6 502 399	2	113, 114, 117, 118, 151, 152
-	111 701 241 A	Guide sleeve - Heating control cable ..... from Chassis No. 1 - 397 023 up to 6 502 399	1	
-	111 701 247	Conduit - Brake cable, front ..... up to Chassis No. 6 502 399	2	111, 112, 115, 116

Key No.	Part No.	Description	Quantity	Type and model
7	111 701 255 B	Guide - Gearshift rod	1	
8	111 701 259 A	Bush - Gearshift rod guide	1	
9	111 701 263	Retaining ring - Gearshift rod guide bush	1	
(10)	111 701 293 A	Rubber packing - Cable guide up to Chassis No. 1 862 188	1	
10	113 701 293 C	Rubber packing - Cable guide from Chassis No. 1 862 189 up to 111 2317 004	1	
-	311 721 363	Rubber sleeve - Clutch cable from Chassis No. 111 2317 005	1	
-	311 721 579	Rubber sleeve - Accelerator cable from Chassis No. 111 2317 005	1	
11	111 701 309	Water drain valve - Tunnel plate from Chassis No. 117 000 001 from Chassis No. 151 2000 001	1 2	151, 152
12	113 701 329	Deformation element - Frame from Chassis No. 111 2000 001	1	113, 114, 117, 118, 151, 152
13	N 12 228 2	Spring washer B 8 from Chassis No. 111 2000 001	8	113, 114, 117, 118, 151, 152
14	N 10 238 7	Bolt, hex. head M 8x15 from Chassis No. 111 2000 001	8	113, 114, 117, 118, 151, 152
-	113 701 347	Plug - Frame from Chassis No. 112 2000 001	2	113, 114, 117, 118, 151, 152
15	111 701 409 A	Hook plate - Battery mounting up to Chassis No. 6 502 399	1	
(15)	113 701 409 A	Hook plate - Battery mounting from Chassis No. 115 000 001	1	
16	111 701 415	Bolt - Battery mounting	1	
(17)	113 701 421 D	Frame - Seat from Chassis No. 1 - 929 746 up to 115 999 000 from Chassis No. 116 000 001 up to 110 3100 000	2 2	113, 114, 117, 118, 151, 152
17	113 801 251	Frame - Seat from Chassis No. 111 2000 001	2	111-118, 151, 152; M 1
-	113 701 425	Seat runner with ratchet up to Chassis No. 1 - 929 745	2	113, 114, 117, 118, 151, 152



Key No.	Part No.	Description	Quantity	Type and model
-	113 701 431	Seat runner without ratchet (elevated) ..... up to Chassis No. 1 - 929 745	1	113, 114 117, 118, 151, 152
-	113 701 435	Seat runner without ratchet ..... up to Chassis No. 1 - 929 745	1	113, 114, 117, 118, 115, 152
-	311 705 127	* Threaded plate - Safety belt mounting on floor ... plate from Chassis No. 115 000 001 up to 116 1021 300 from Chassis No. 117 000 001	2 2	M 17
-	311 701 449	* Threaded plate - Safety belt mounting on floor ... plate up to Chassis No. 6 502 399	2	M 17
-	113 701 453	Support - Heater pipe, rear ..... from Chassis No. 4 010 995 up to 5 199 979	2	113, 114, 117, 118, 151, 152
-	111 701 455	Screw - Front seal mounting ..... up to Chassis No. 115 999 000	4	111, 112, 115, 116
18	111 701 475 A	Socket - Jack .....	2	111-118
(19)	111 701 495	Stud, lower part - Floor plate ..... up to Chassis No. 1 - 929 745	8	
19	111 701 495 A	Stud, lower part - Floor plate ..... from Chassis No. 1 - 929 746 up to 2 528 667 from Chassis No. 2 528 668 up to 115 999 000	8 8	111, 112, 115, 116
20	111 701 535 A	Bracket for accelerator pedal on floor plate ..... from Chassis No. 1 600 440	1	
21	111 701 555 B	Inspection cover (frame fork) .....	1	
22	N 13 961 2	Tapping screw, fillister head B 3.9x13 .....	2	
(23)	113 701 565	Cover - Frame head ..... up to Chassis No. 1 - 929 745 from Chassis No. 1 - 929 746 up to 4 630 937	1 1	111, 112, 115, 116
(24)	N 10 349 2	Bolt, hex. head BM 6x45 .....	2	
(25)	N 11 695 2	Washer 6.1 .....	2	
(23)	113 701 565 A	Cover - Frame head ..... from Chassis No. 1 - 929 746 up to 4 630 937 from Chassis No. 4 630 938 up to 115 999 000	1 1	113, 114, 117, 118, 151, 152



Key No.	Part No.	Description	Quantity	Type and model
23	131 701 565	Cover - Frame head ..... from Chassis No. 116 000 001 up to 110 3100 000 from Chassis No. 111 2000 001	1 1	111, 112, 115, 116; M 1
24	N 10 212 3	Bolt, hex. head M 6×12 ..... up to Chassis No. 110 3100 000 from Chassis No. 111 2000 001	2 2	111, 112, 115, 116; M 1
25	211 805 243	Spring washer B 6 ..... up to Chassis No. 110 3100 000 from Chassis No. 111 2000 001	2 2	111, 112, 115, 116; M 1
(27)	113 701 571	Gasket - Frame head cover ..... up to Chassis No. 115 999 000	1	
26	113 701 571 A	Gasket - Frame head cover ..... from Chassis No. 111 2000 001	1	113, 114, 117, 118, 151, 152
27	131 701 571	Gasket - Frame head cover ..... from Chassis No. 116 000 001 up to 110 3100 000 from Chassis No. 111 2000 001	1 1	111, 112, 115, 116; M 1
28	113 701 605	Weatherstrip between body and frame ..... up to Chassis No. 119 1200 000 from Chassis No. 110 2000 001 up to 110 3100 000 from Chassis No. 111 2000 001	1 1 1	111-118
(28)	141 701 605 B	Weatherstrip between body and frame ..... from Chassis No. 150 2000 001 up to 150 3100 000	1	151, 152
29	111 701 621	Sealing strip - Frame fork ..... 1	1	
30	111 701 625	Tapping screw ..... up to Chassis No. 110 3100 000	36	
-	111 701 913	Bracket - Shock absorber mounting, left ..... (for service installation of telescopic shock absorbers)	1	111-118
-	111 701 914	Bracket - Shock absorber mounting, right ..... (for service installation of telescopic shock absorbers)	1	111-118
-	N 10 120 2	Bolt, hex. head M 12×1.5×20 ..... 4	4	111-118
-	N 12 012 2	Lock washer B 12 ..... 4	4	111-118

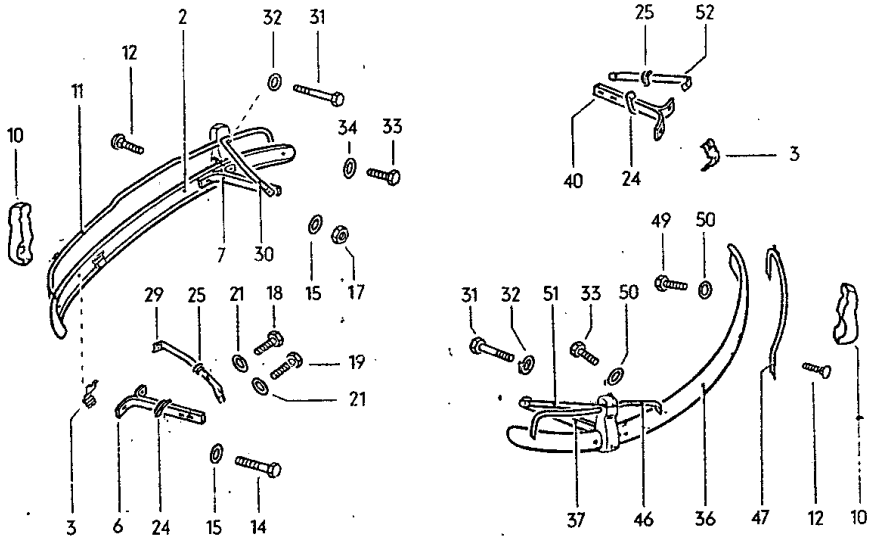
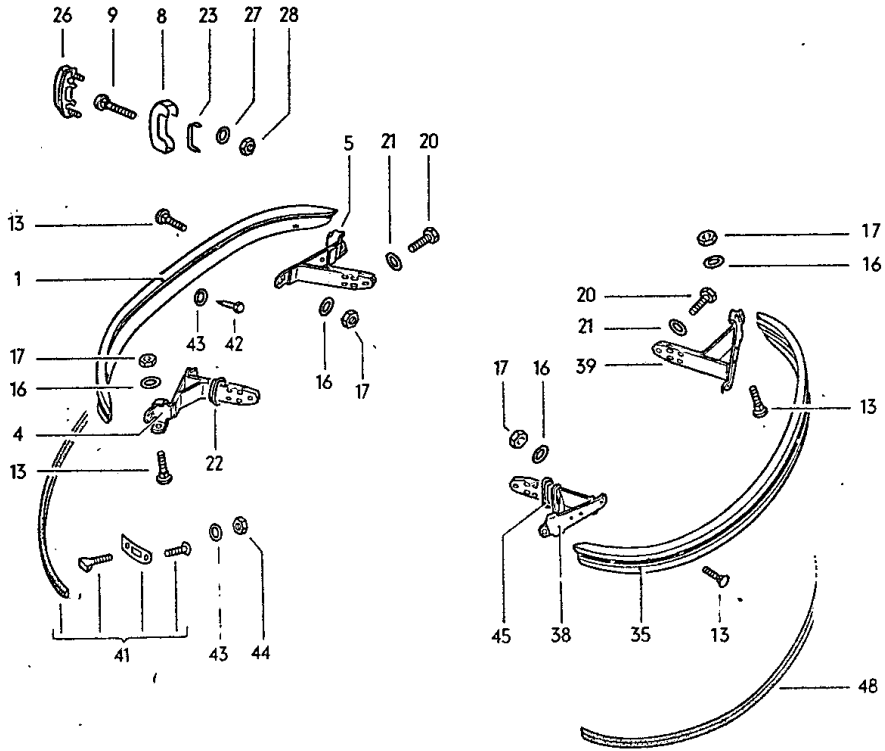

Key No.	Part No.	Description	Quantity	Type and model
<b>BUMPERS</b>				
1	113 707 103 D	Bumper, front, chromium plated from Chassis No. 118 000 001	1	113, 114, 117, 118, 151, 152
(2)	111 707 111 A	Bumper, front up to Chassis No. 117 999 000	1	111, 112, 115, 116
(1)	111 707 111 C	Bumper, front, primed from Chassis No. 118 000 001	1	M 149: 113, 114, 117, 118
(2)	113 707 111 A	Bumper, front, chromium plated up to Chassis No. 117 999 000 from Chassis No. 118 000 001	1 1	113, 114, 117, 118, 151, 152 111, 112, 115, 116
2	113 707 111 B	Bumper, front, chromium plated (bumper guard)	1	M 107
3	*111 707 121	Reinforcement - Bumper from Chassis No. 1 - 397 023 up to 117 999 000 from Chassis No. 118 000 001	8 8	111, 112, 115, 116
4	111 707 133 B	Bracket - Bumper (front left) from Chassis No. 111 2000 001	1	113, 114, 117, 118, 151, 152
(4)	111 707 133 C	Bracket - Bumper (front left) from Chassis No. 118 000 001 up to 110 3100 000 from Chassis No. 111 2000 001	1 1	113, 114, 117, 118, 151, 152 M 1
5	111 707 134 A	Bracket - Bumper (front right ) from Chassis No. 111 2000 001	1	113, 114, 117, 118, 151, 152
(5)	111 707 134 C	Bracket - Bumper (front right ) from Chassis No. 118 000 001 up to 110 3100 000 from Chassis No. 111 2000 001	1 1	113, 114, 117, 118, 151, 152 M 1
6	*111 707 135 A	Bracket - Bumper (front left) (center punch identification) up to Chassis No. 117 999 000 from Chassis No. 118 000 001	1 1	111, 112, 115, 116
7	*111 707 136 A	Bracket - Bumper (front right) up to Chassis No. 117 999 000 from Chassis No. 118 000 001	1 1	111, 112, 115, 116



Key No.	Part No.	Description	Quantity	Type and model
8	113 707 153	Override - Bumper, front, right/rear left .....	2	M 58
(8)	113 707 154	Override - Bumper, front, left/rear right .....	2	M 58
9	N 10 525 1	Screw M 8×50 .....	4	M 58
(10)	111 707 155 A	Override - Bumper 111 707 111 A/311 A .....	4	111, 112, 115, 116 up to Chassis No. 117 999 000
(10)	113 707 155 A	Override - Bumper 113 707 111 A/311 A .....	4	113, 114, 117, 118, 151, 152; M 110 up to Chassis No. 117 999 000
10	*113 707 155 B *	Override - Bumper 113 707 111 B/311 B .....	4	M 107
11	*113 707 177 *	Bow - Bumper 113 707 111 B .....	1	M 107
(12)	113 707 191	Screw - Bumper 111/113 707 111/311 .....	4	up to Chassis No. 1 - 397 022
12	*113 707 191 B	Screw - Bumpers 111 707 111 A, 113 707 111 A/B, ..	4	111, 112, 115, 116
		111 707 311 A/E, 113 707 311 A/B from Chassis No. 1 - 397 023 up to 117 999 000	8	
13	113 707 191 C	Screw - Bumpers M 8×15 .....	12	113, 114, 117, 118, 151, 152 from Chassis No. 118 000 001
14	N 10 269 1	Bolt, hex. head M 8×38 .....	2	up to Chassis No. 117 999 000
15	N 12 241 2	Spring washer B 8×15 .....	4	111, 112, 115, 116
		up to Chassis No. 117 999 000 from Chassis No. 118 000 001	4	
16	211 821 149	Spring washer 8.1×24 galvanized .....	12	113, 114, 117, 118, 151, 152 from Chassis No. 118 000 001
17	N 11 008 8	Nut, hex. M 8 .....	6	111, 112, 115, 116
		up to Chassis No. 117 999 000	8	
		from Chassis No. 118 000 001 from Chassis No. 118 000 001	12	

Key No.	Part No.	Description	Quantity	Type and model
18	N 10 241 3	Bolt, hex. head M 8×22 ..... up to Chassis No. 117 999 000 from Chassis No. 118 000 001	8 8	111, 112, 115, 116
19	N 10 244 8	Bolt, hex. head M 8×30 .....	4	M 107
20	N 10 239 0 550 N102391-1	Bolt, hex. head M 8×18 ..... from Chassis No. 118 000 001 from Chassis No. 118 000 001	12 4	113, 114, 117, 118, 151, 152 111, 112, 115, 116
21	211 821 149	Spring washer 8,1×24 galvanized ..... up to Chassis No. 117 999 000 from Chassis No. 118 000 001 from Chassis No. 118 000 001	8 8 12	111, 112, 115, 116 113, 114, 117, 118, 151, 152
22	111 707 193	Grommet – Bumper bracket, front ..... from Chassis No. 111 2000 001	2	113, 114, 117, 118, 151, 152
23	113 707 195	Beading – Override .....	8	M 58
24	*111 707 197 A	Grommet – Bumper bracket front/rear ..... up to Chassis No. 117 999 000 from Chassis No. 118 000 001	4 4	111, 112, 115, 116
(22)	111 707 197 B	Grommet – Bumper bracket ..... from Chassis No. 118 000 001 up to 110 3100 000 from Chassis No. 111 2000 001	2 2	113, 114, 117, 118, 151, 152 M 1
25	*111 707 199 A	* Seal – Override support .....	4	M 107
26	113 707 217	Rubber molding – Override .....	4	M 58
27	N 12 005 1	Lock washer B 5 .....	16	M 58
28	N 11 005 2	Nut, hex. ....	16	M 58
29	*113 707 233	* Support, front, left – Override 113 707 155 B .....	1	M 107
30	*113 707 234	* Support, front, right – Override 113 707 155 B ...	1	M 107
31	N 10 350 3	Bolt, hex. head BM 8×50 .....	4	M 107



Key No.	Part No.	Description	Quantity	Type and model
32	N 12 241 2	Spring washer B 8×15 .....	4	M 107
33	N 10 239 0	Bolt, hex. head M 8×18 .....	6	M 107
34	N 12 241 2	Spring washer B 8×15 .....	6	M 107
35	113 707 303	Bumper, rear, chromium plated from Chassis No. 118 000 001 .....	1	113, 114, 117, 118, 151, 152
(36)	111 707 311 A	Bumper, rear .....	1	111, 112, 115, 116
		up to Chassis No. 117 999 000		
(35)	111 707 311 D	Bumper, rear, primed .....	1	M 149: 113, 114, 117, 118
		from Chassis No. 118 000 001		
(36)	111 707 311 E	Bumper, rear, chromium .....	1	M 86
		from Chassis No. 117 483 306 up to 117 999 000	1	111, 112, 115, 116
		from Chassis No. 118 000 001		
(36)	113 707 311 A	Bumper, rear, chromium plated .....	1	113, 114, 117, 118, 151, 152; M 110
		up to Chassis No. 117 999 000		
36	*113 707 311 B *	Bumper, rear, chromium plated .....	1	M 107
		(Bumper guard)		
37	111 707 333 A	Bracket - Bumper (rear left) .....	1	111, 112, 115, 116
		from Chassis No. 111 2000 001		
38	113 707 333 A	Bracket - Bumper (rear left) .....	1	113, 114, 117, 118, 151, 152
		from Chassis No. 118 000 001		
39	113 707 334 A	Bracket - Bumper (rear right) .....	1	113, 114, 117, 118, 151, 152
		from Chassis No. 118 000 001		
(37)	*111 707 335 B	Bracket - Bumper (rear left) .....	1	111, 112, 115, 116
		up to Chassis No. 117 999 000	1	
		from Chassis No. 118 000 001 up to 110 3100 000	1	
		(center punch identification)		
40	111 707 336 A	Bracket - Bumper (rear right) .....	1	111, 112, 115, 116
		from Chassis No. 111 2000 001		

Key No.	Part No.	Description	Quantity	Type and model
(40)	*111 707 336 B	Bracket - Bumper (rear right) ..... up to Chassis No. 117 999 000 from Chassis No. 118 000 001 up to 110 3100 000	1 1	111, 112, 115, 116
(41)	113 707 201	Rubber molding - Bumper, front ..... up to Chassis No. 110 3100 000	1	M 603
41	113 707 201 A	Rubber molding - Bumper, front ..... from Chassis No. 111 2000 001	1	151, 152: M 162, M 602, M 603
42	411 707 199	Tapping screw, hex. head - Rubber molding ..... mounting from Chassis No. 151 2000 001	2 2	M 162, M 602, M 603 151, 152
43	N 11 524 4	Washer A 6.4 ..... from Chassis No. 151 2000 001	6 6	M 162, M 602, M 603 151, 152
44	N 11 006 2	Nut, hex. M 6 ..... from Chassis No. 151 2000 001	4 4	M 162, M 602, M 603 151, 152
45	111 707 197 B	Grommet - Bumper bracket ..... from Chassis No. 118 000 001	2	113, 114, 117, 118, 151, 152
(46)	113 707 385	* Bow, rear, left ..... up to Chassis No. 117 171 364	1	M 107
46	113 707 385 A	* Bow, rear, left ..... from Chassis No. 117 171 365	1	M 107
(47)	113 707 386	* Bow, rear, right ..... up to Chassis No. 117 171 364	1	M 107
47	113 707 386 A	* Bow, rear, right ..... from Chassis No. 117 171 365	1	M 107
48	113 707 401	Rubber molding - Bumper, rear ..... from Chassis No. 151 2000 001	1 1	M 162, M 602, M 603 151, 152
-	415 707 401	Adhesive tape, black - Bumper ..... from Chassis No. 118 000 001	2	
49	N 10 241 3	Bolt, hex. head M 8x22 ..... up to Chassis No. 117 999 000 from Chassis No. 118 000 001	2 2	M 107



Key No.	Part No.	Description	Quantity	Type and model
50	N 12 241 2	Spring washer B 8X15 ..... up to Chassis No. 117 999 000 from Chassis No. 118 000 001	6 4	111, 112, 115, 116
51	113 707 391	* Support, rear, left – Override 113 707 155 B .....	1	M 107
52	113 707 392	* Support, rear, right – Override 113 707 155 B .....	1	M 107





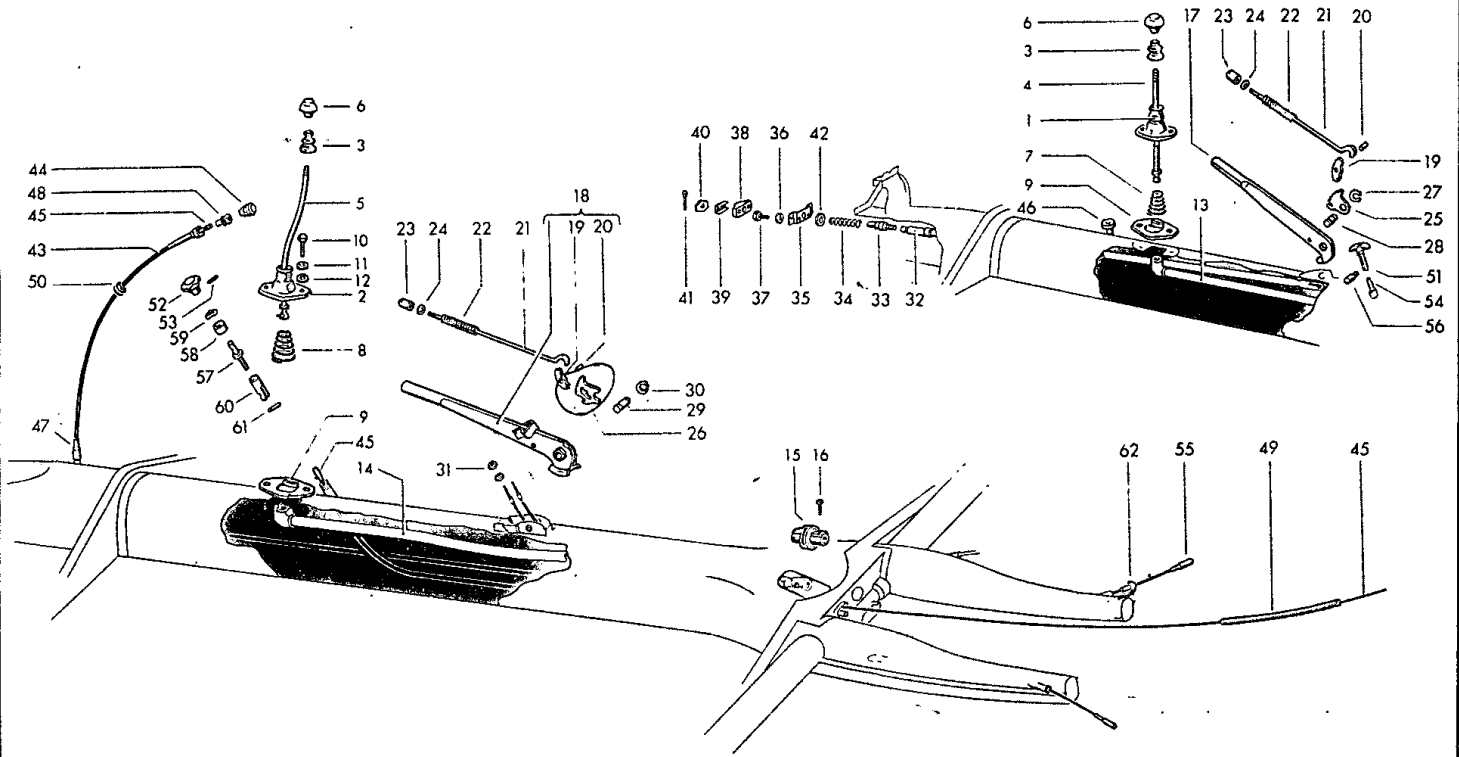



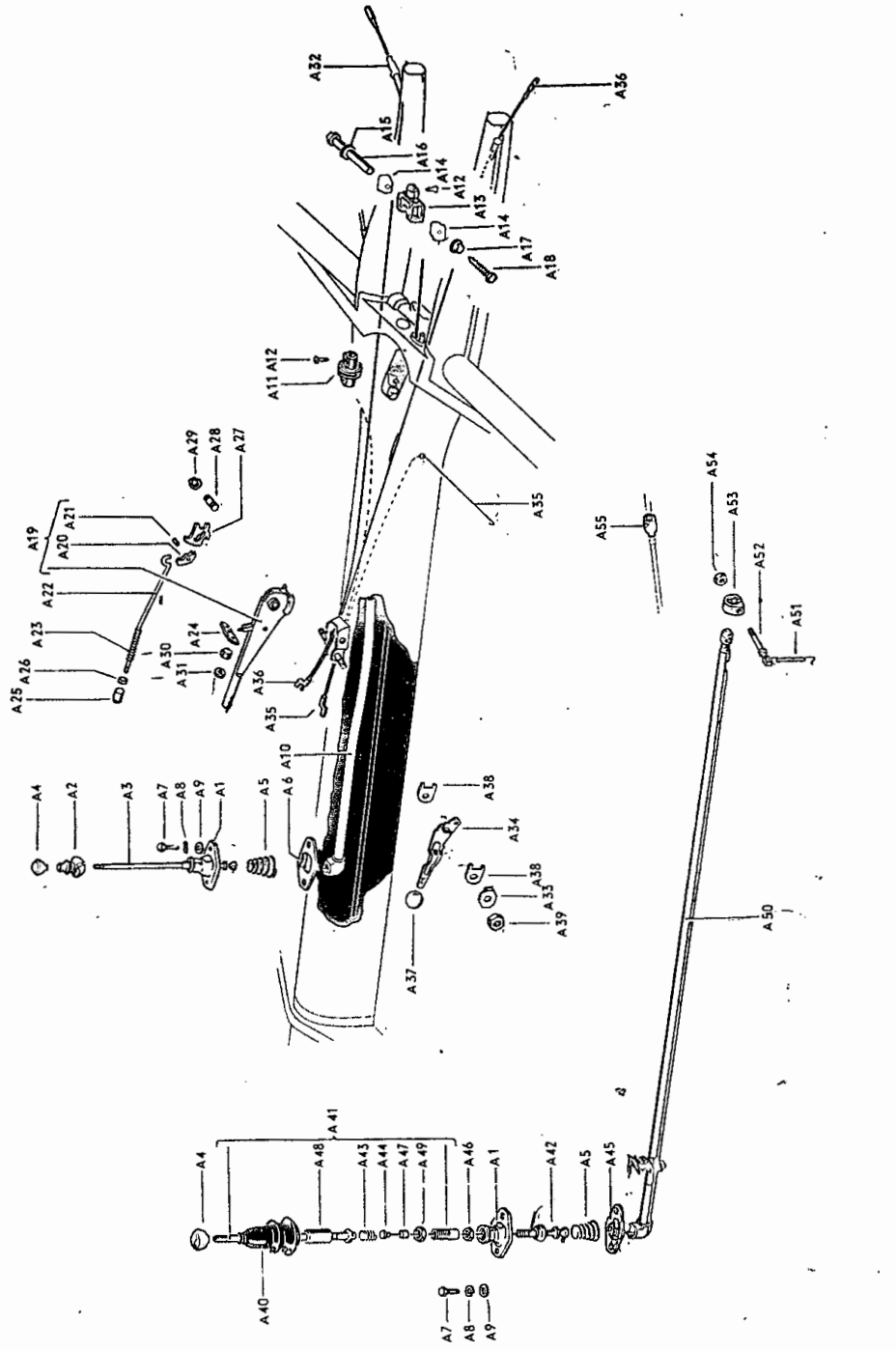

Illustration A37

Key No.	Part No.	Description	Quantity	Type and model
<b>HAND LEVER SYSTEM</b>				111-118, 141-144, 151, 152 M 9: 113, 114, 117, 118, 141-144, 151, 152 M 9/M 87: 113, 114, 117, 118, 151, 152 M 9/M 52: 111, 112, 115, 116 M1/M 9: 113, 114, 117, 118
		from Chassis No. 118 071 440		
		from Chassis No. 119 000 001		
		from Chassis No. 110 2000 001		
		from Chassis No. 111 2000 001		
1	211 711 105	Ball housing - Gearshift lever ..... up to Chassis No. 1 - 397 022	1	
2/A 1	111 711 105	Ball housing - Gearshift lever ..... from Chassis No. 1 - 397 023 up to 111 3200 000	1	
-	111 711 105 A	Ball housing - Gearshift lever ..... from Chassis No. 112 2000 001	1	
3/A 2	111 711 115 A	Rubber boot - Gearshift lever ..... 444 malachite green - 61, 76 8/60 - 2/61 444 malachite green - 58, 62, 74, 77 8/60 - 7/62 026 honey brown - 58, 60, 74, 77 8/60 - 7/62 469 anthracite - 59, 65, 75, 78 8/60 - 7/63 043 grey black 8/63 - 7/64 043 grey black 8/64 - 7/65 469 anthracite 8/64 - 7/65  026 honey brown - 59, 63, 78, 80 8/60 - 7/63 444 malachite green - 58, 62, 74, 77 8/60 - 7/62 469 anthracite - 57, 61, 75, 76 8/60 - 7/62 043 grey black 8/62 - 7/64 043 grey black 8/65 -	1 1	113, 114, 117, 118, 151, 152 141-144 113, 114, 117, 118, 151, 152 111-118, 151, 152 111-118, 151, 152 111, 112, 115, 116 113, 114, 117, 118, 141-144, 151, 152 141-144 141-144 141-144 141-144
-	141 711 115	Rubber boot - Gearshift lever ..... up to Chassis No. 146 1021 300 264 rock grey 8/60 - 7/62 043 grey black 8/62 - 7/64 469 anthracite 8/64 - 7/65 043 grey black 8/65 - 7/66	1	M 59: 141-144
4	111 711 121	Gearshift lever ..... up to Chassis No. 1 - 397 022	1	
-	111 711 121 A	Gearshift lever ..... from Chassis No. 1 - 397 023 up to 1 - 929 745	1	
5	111 711 121 F SS by 111 711 121 G	Gearshift lever ..... from Chassis No. 1 - 929 746 up to 117 999 000 use: 141 711 141 D (043)	1	111-118, 151, 152



Key No.	Part No.	Description	Quantity	Type and model
A 3	113 711 121 A	Gearshift lever ..... from Chassis No. 118 000 001	1	
-	141 711 121 C	Gearshift lever ..... up to Chassis No. 117 999 000	1	141-144
-	113 711 125 D	Gearshift lever - Lower part (Saxomat) ..... up to Chassis No. 117 999 000	1	M 5: 111-118, 151, 152
-	141 711 125 E	Gearshift lever - Lower part (Saxomat) ..... up to Chassis No. 117 999 000	1	M 5: 141-144
-	113 711 141	Knob - Gearshift lever ..... up to Chassis No. 1 - 929 745	1	
		from Chassis No. 1 - 929 746 up to 4 289 951	1	111, 112, 115, 116
		from Chassis No. 115 000 001 up to 117 999 000	1	M 5
	5/50 - 7/67	466 silver beige		
6	113 711 141 A	Knob - Gearshift lever ..... from Chassis No. 1 - 929 746 up to 4 289 951	1	113, 114, 117, 118, 151, 152
		from Chassis No. 4 289 952 up to 117 999 000	1	111-118, 141-144, 151, 152
	8/63 - 7/66	466 silver beige		
	8/66 - 7/67	043 grey black		
A 4	141 711 141 D	Knob - Gearshift lever ..... from Chassis No. 118 000 001	1	
	8/67 -	043 grey black		
7	211 711 145 A	Spring - Gearshift lever ..... up to Chassis No. 1 - 397 022	1	
8/A 5	111 711 145 B	Spring - Gearshift lever ..... from Chassis No. 1 - 397 023	1	
9/A 6	111 711 149 A	Stop - Gearshift lever ..... up to Chassis No. 111 3200 000	1	
	550y 111 711 149 B	Stop - Gearshift lever ..... from Chassis No. 112 2000 001	1	
10/A 7	N 10 240 4	Bolt, hex. head M 8x20 .....	2	
11/A 8	131 821 150	Spring washer .....	2	
12/A 9	N 11 654 2	Washer 9.5 .....	2	
13	111 711 155	Gearshift rod ..... up to Chassis No. 1 - 397 022	1	
-	111 711 155 A	Gearshift rod ..... from Chassis No. 1 - 397 023 up to 1 - 929 745	1	

Key No.	Part No.	Description	Quantity	Type and model
14	111 711 155 D	Gearshift rod ..... from Chassis No. 1 - 929 746 up to 6 502 399	1	
-	111 711 155 E	Gearshift rod ..... from Chassis No. 115 000 001 up to 117 999 000	1	
A 10	113 711 155	Gearshift rod ..... from Chassis No. 118 000 001	1	
15/A 11	111 711 175 B	Coupling - Gearshift rod ..... up to Chassis No. 5 911 560	1	113, 114, 117, 118, 141-144, 151, 152
		up to Chassis No. 115 247 528	1	111, 112, 115, 116
16/A 12	111 711 189	Screw - Gearshift rod coupling ..... up to Chassis No. 115 247 528	2	
		from Chassis No. 115 247 529	1	
A 13	311 711 211	Housing - Gearshift rod coupling ..... from Chassis No. 5 911 561 up to 115 247 528	1	113, 114, 117, 118, 141-144, 151, 152
		from Chassis No. 115 247 529	1	
-	311 711 227	Washer 10x16 ..... from Chassis No. 5 911 561 up to 115 247 528	1	113, 114, 117, 118, 141-144, 151, 152,
		from Chassis No. 115 247 529	1	
A 14	311 711 233 SS UY 823711477	Guide ring (rubber) - Gearshift rod coupling .... from Chassis No. 5 911 561 up to 115 247 528	2	113, 114, 117, 118, 141-144, 151, 152
		from Chassis No. 115 247 529	2	
A 15	N 11 560 2	Washer 10.5 ..... from Chassis No. 116 412 701	1	
A 16	311 711 235 A	Sleeve - Gearshift rod coupling ..... from Chassis No. 5 911 561 up to 115 247 528	1	113, 114, 117, 118, 141-144, 151, 152
		from Chassis No. 115 247 529	1	
A 17	311 711 239	Locking cap - Hex. head tapping screw ..... from Chassis No. 5 911 561 up to 115 247 528	1	113, 114, 117, 118, 141-144, 151, 152
		from Chassis No. 115 247 529	1	
A 18	311 711 243	Tapping screw, hex. head ..... from Chassis No. 5 911 561 up to 115 247 528	1	113, 114, 117, 118, 141-144, 151, 152
		from Chassis No. 115 247 529	1	



Key No.	Part No.	Description	Quantity	Type and model
17	111 711 305	Lever - Hand brake .....	1	111-118, 151, 152
		up to Chassis No. 1 - 929 745	1	111, 112, 115, 116
		from Chassis No. 1 - 929 746 up to 4 630 937		
18	113 711 305	Lever - Hand brake .....	1	113, 114, 117, 118,
		from Chassis No. 1 - 929 746 up to 4 630 937	1	141-144, 151, 152
		from Chassis No. 4 630 938 up to 115 400 108	1	
-	113 711 305 A	Lever - Hand brake .....	1	
		from Chassis No. 115 400 109 up to 117 999 000		
A 19	311 711 305	Lever - Hand brake .....	1	
		from Chassis No. 118 000 001 up to January 1972		
-	311 711 305 A	Lever - Hand brake .....	1	
		from Chassis No. February 1972		
19/A 20	111 711 321	Pawl - Hand brake .....	1	
20/A 21	111 711 323	Pin - Hand brake pawl .....	1	
21	111 711 325	Rod - Hand brake pawl .....	1	
		up to Chassis No. 117 999 000		
A 22	311 711 325	Rod - Hand brake pawl .....	1	
		from Chassis No. 118 000 001		
22/A 23	111 711 329	Spring - Pawl rod .....	1	
A 24	111 711 331	Compensating lever - Hand brake lever .....	1	
		from Chassis No. 115 400 109		
23/A 25	113 711 333 A	Release button - Hand brake lever .....	1	
		up to Chassis No. 112 2005 693		
		466 silver beige		
		043 grey black		
		<i>SS 07 103-711-333B</i> 5/50 - 7/66 8/66 -		
-	113 711 333 B	Release button - Hand brake lever .....	1	
		from Chassis No. 112 2005 694		
24/A 26	111 711 335	Washer - Hand brake lever .....	1	
		up to Chassis No. 112 2005 693		
25	111 711 339	Ratchet - Hand brake .....	1	111-118, 151, 152
		up to Chassis No. 1 - 929 745	1	111, 112, 115, 116
		from Chassis No. 1 - 929 746 up to 4 630 937		
26	211 711 339	Ratchet - Hand brake .....	1	113, 114, 117, 118,
		from Chassis No. 1 - 929 746 up to 4 630 937	1	141-144, 151, 152
		from Chassis No. 4 630 938 up to 6 502 399	1	



Key No.	Part No.	Description	Quantity	Type and model
A 27	131 711 339	Ratchet - Hand brake ..... from Chassis No. 115 000 001	1	
27	N 12 415 1	Lockring 15×1 .....	2	111-118, 151, 152
28	111 711 341	Pin - Hand brake lever ..... up to Chassis No. 1 - 929 745 from Chassis No. 1 - 929 746 up to 4 630 937	1 1	111-118, 151, 152 111, 112, 115, 116
29/A 28	113 711 341	Pin - Hand brake lever ..... from Chassis No. 1 - 929 746 up to 4 630 937  from Chassis No. 4 630 938	1 1	113, 114, 117, 118, 141-144, 151, 152
30/A 29	N 12 460 1	Circlip 14 .....	2	
A 30	111 711 349	Adjusting nut - Rear brake ..... from Chassis No. 115 400 109	2	
31/A 31	N 11 006 2	Nut, hex. M 6 ..... up to Chassis No. 115 400 108 from Chassis No. 115 400 109	4 2	
-	111 711 357	Push bar without end piece ..... up to Chassis No. 4 630 937		111, 112, 115, 116
32	113 711 357	Push bar without end piece ..... up to Chassis No. 1 - 929 745	1	113, 114, 117, 118, 151, 152
33	111 711 369	End piece - Push bar ..... up to Chassis No. 1 - 929 745 from Chassis No. 1 - 929 746 up to 4 630 937	1 1	111-118, 151, 152 111, 112, 115, 116
34	113 711 375	Spring - Push bar ..... up to Chassis No. 1 - 929 745	1	113, 114, 117, 118, 151, 152
35	113 711 377	Guide plate - Brake push bar ..... up to Chassis No. 1 - 397 022	1	113, 114, 117, 118, 151, 152
-	113 711 377 A	Guide plate - Brake push bar ..... from Chassis No. 1 - 397 023 up to 1 - 929 745	1	113, 114, 117, 118, 151, 152
36	N 12 226 2	Spring washer B 6 .....	2	113, 114, 117, 118, 151, 152



Key No.	Part No.	Description	Quantity	Type and model
37	N 10 212 3	Bolt, hex. head M 6×12 .....	2	113, 114, 117, 118, 151, 152
38	113 711 381	Junction head – Push bar .....	1	113, 114, 117, 118, 151, 152
		up to Chassis No. 1 – 929 745		
39	113 711 385 A	Lock plate – Junction head .....	1	113, 114, 117, 118, 151, 152
		up to Chassis No. 1 – 929 745		
40	111 721 199	Plate – Junction head .....	1	113, 114, 117, 118, 151, 152
		up to Chassis No. 1 – 929 745		
41	N 12 522 1	Cotter pin 2×22 .....	1	113, 114, 117, 118, 151, 152
42	113 711 387	Washer – Push bar .....	1	113, 114, 117, 118, 151, 152
		up to Chassis No. 1 – 929 745		
–	111 711 501	Cable – Choke control (3770 mm – 148 7/16 in.) ...	1	111-118, 151, 152
		from Chassis No. 1 – 397 023 up to 1 – 459 216		
43	111 711 501 A	Cable – Choke control (3770 mm – 148 7/16 in.) ...	1	111-118, 151, 152
		from Chassis No. 1 – 459 217 up to 3 192 506	1	111, 112, 115, 116
		from Chassis No. 3 192 507 up to 115 999 000	1	
–	141 711 501	Cable – Choke control (4095 mm – 161 7/32 in.) ...	1	141-144
		up to Chassis No. 3 192 506		
–	111 941 541	Knob – Choke control cable (black) .....	1	111, 112, 115, 116
		from Chassis No. 1 – 397 023 up to 5 677 118		
44	113 941 541	Knob – Choke control cable .....		
		from Chassis No. 1 – 397 023 up to 3 192 506	1	113, 114, 117, 118, 151, 152
		up to Chassis No. 1 649 252	1	141, 143
		from Chassis No. 5 677 119 up to 115 999 000	1	111, 112, 115, 116
		567 ivory		
		466 silver beige		
	8/55 - 7/60			
	8/63 - 7/65			
–	141 941 541	Knob – Choke control cable (white) .....	1	141-144
		from Chassis No. 1 649 253 up to 3 192 506		
45	141 711 505	Cable for choke .....		
		from Chassis No. 1 – 397 023 up to 3 192 506	1	
		from Chassis No. 3 192 507 up to 115 999 000	1	111, 112, 115, 116
46	241 711 505	Cable – Choke control, ivory (2420 mm – ...)	1	111-118, 151, 152
		95 7/32 in.)		
		up to Chassis No. 1 – 397 022		



Key No.	Part No.	Description	Quantity	Type and model
47		no longer available		
48	111 711 517	Escutcheon with rubber washer - Choke cable ... 111 711 501 A/141 711 501 from Chassis No. 1 - 397 023 up to 3 192 506 from Chassis No. 3 192 507 up to 115 999 000	1 1	111, 112, 115, 116
49	111 711 531	Sleeve - Choke control cable ..... from Chassis No. 1 - 397 023 up to 115 999 000	1	
50	111 711 535	Grommet - Choke control cable (through panel) from Chassis No. 1 - 397 023 up to 3 192 506 from Chassis No. 3 192 507 up to 115 999 000	1 1	111, 112, 115, 116
-	111 711 605	Cable - Heating control (single control) ..... (1696 mm - 66 <sup>25</sup> / <sub>32</sub> in.) up to Chassis No. 1 - 091 914	1	111, 112
-	113 711 607	Cable - Heating control (dual control) ..... (1696/1620 mm - 66 <sup>25</sup> / <sub>32</sub> / 63 <sup>25</sup> / <sub>32</sub> in.) from Chassis No. 1 - 091 915 up to 1 - 162 443	1	111-118, 151, 152
-	113 711 607 A	Cable - Heating control (with ivory knob) ..... (dual control) (1614/1538 mm - 63 <sup>17</sup> / <sub>32</sub> / 60 <sup>9</sup> / <sub>16</sub> in.) from Chassis No. 1 - 091 915 up to 1 - 162 443	1	111-118, 151, 152
51	111 711 611	Knob black - Heating control cable ..... from Chassis No. 1 - 162 444 up to 1 - 397 022	1	111-118, 151, 152
52	113 711 623 A 10/52 - 7163 10/52 - 7164	Knob - Heating ..... from Chassis No. 1 - 397 023 up to 6 502 399 567 ivory 466 silver beige	1	
53	N 13 328 1	Pin 3X20 .....	1	
-	111 711 629	Cable - Heating control (2843 mm - 111 <sup>15</sup> / <sub>16</sub> in) from Chassis No. 1 - 162 444 up to 1 - 243 730	1	111-118, 151, 152
54	111 711 629 A	Cable - Heating control (2668 mm - 105 <sup>1</sup> / <sub>32</sub> in.) .. from Chassis No. 1 - 243 731 up to 1 - 929 745	1	111-118, 151, 152
-	111 711 629 B	Cable - Heating control (3670 mm - 144 <sup>1</sup> / <sub>2</sub> in.) ... from Chassis No. 1 - 929 746 up to 5 199 979	1	
55	111 711 629 E	Cable - Heating control (3660 mm - 144 <sup>3</sup> / <sub>32</sub> in.) .. from Chassis No. 5 199 980 up to 6 502 399	1	
56	111 711 655 A	Bolt - Heating control cable ..... from Chassis No. 1 - 162 444 up to 1 - 397 022	1	111-118, 151, 152
57	111 711 671 A	Spindle - Heating control cable ..... from Chassis No. 1 - 397 023 up to 6 502 399	1	



Key No.	Part No.	Description	Quantity	Type and model
58	111 711 675	Cap - Heating control cable ..... from Chassis No. 1 - 397 023 up to 6 502 399	1	
59	111 711 677	Spring washer ..... from Chassis No. 1 - 397 023 up to 6 502 399	1	
60	111 711 681	Clevis - Heating control cable ..... from Chassis No. 1 - 397 023 up to 6 502 399	1	
61	N 13 216 1	Cable pin 4x14 ..... from Chassis No. 1 - 397 023 up to 6 502 399	1	
-	111 711 687	Retaining spring - Choke ..... and heating control cables (single control) up to Chassis No. 1 - 162 443	1	111, 112
62/A 32	113 711 691	Grommet .....	2	
A 33	131 711 665	Stop - Lever ..... from Chassis No. 115 000 001	2	
A 34	111 711 711 B	Lever, left - Heating ..... from Chassis No. 115 000 001	1	
-	111 711 712 B	Lever, right - Heating ..... from Chassis No. 115 000 001	1	
A 35	111 711 713	Cable - Foot well heating rear ..... from Chassis No. 115 000 001	1	
A 36	*111 711 717 <i>hand</i>	Cable - Heating control ..... from Chassis No. 115 000 001 up to 110 3100 000 from Chassis No. 111 2000 001	1 1	111, 112, 115, 116, 141-144; M 1
-	111 711 717 A <i>Antenna</i>	Cable - Heating control ..... up to Chassis No. 110 3100 000 from Chassis No. 111 2000 001	1 1	M 9 113, 114, 117, 118, 151, 152; M 9
-	131 711 741	Knob silver beige - Lever ..... from Chassis No. 115 000 001 up to 115 999 000	1	
-	*131 711 741 A	Knob red - Lever ..... from Chassis No. 115 000 001 up to 115 999 000	1	
-	113 819 681	Knob - Lever, left ..... from Chassis No. January 1972	1	M 23: 113, 117, 151; M 108, M 110
-	113 819 682	Knob - Lever, right ..... from Chassis No. January 1972	1	M 23: 113, 117, 151; M 108, M 110

Key No.	Part No.	Description	Quantity	Type and model
A 37	131 711 741 B	Knob - Lever .....	1	
		from Chassis No. 116 000 001 up to 117 999 000	2	
	043	grey black		
A 38	*111 711 749 A	Friction plate .....	4	
		from Chassis No. 115 000 001		
A 39	311 101 463	Nut, hex. M 8 (self locking) .....	2	
		from Chassis No. 115 000 001		
A 40	113 713 115	Boot - Gearshift lever .....	1	M 9, M 1/M 9
A 41	113 713 123	Gearshift lever, upper, part .....	1	M 9, M 1/M 9
A 42	113 713 129	Gearshift lever, lower, part .....	1	M 9, M 1/M 9
A 43	113 713 139	Spring .....	1	M 9, M 1/M 9
A 44	113 713 145	Contact - Gearshift lever .....	1	M 9, M 1/M 9
A 45	113 713 149 A	Stop - Gearshift lever .....	1	M 9, M 1/M 9
		up to Chassis No. 111 3200 000		
-	113 713 149 B	Stop - Gearshift lever .....	1	M 9, M 1/M 9
		from Chassis No. 112 2000 001		
A 46	113 713 153	Nut M 15 .....	1	M 9, M 1/M 9
A 47	113 713 155	Insulating sleeve .....	1	M 9, M 1/M 9
A 48	113 713 157	Threaded sleeve - Gearshift lever, upper part ...	1	M 9, M 1/M 9
A 49	113 713 163	Nut M 19 .....	1	M 9, M 1/M 9
A 50	113 713 355	Selector shaft .....	1	M 9, M 1/M 9
A 51	113 713 367	Spring - Selector shaft .....	1	M 9, M 1/M 9
A 52	113 713 369	Screw - Selector shaft spring .....	1	M 9, M 1/M 9
A 53	111 415 539	Clamp - Selector shaft .....	1	M 9, M 1/M 9
A 54	311 101 463	Nut, hex. M 8 (self locking) .....	1	M 9, M 1/M 9
A 55	311 721 579	Rubber sleeve - Accelerator cable .....	1	M 9, M 1/M 9

MAIN GROUP



FRAME HAND LEVER SYSTEM,  
PEDAL CLUSTER

Pedal cluster  
up to Chassis No. 1 600 439

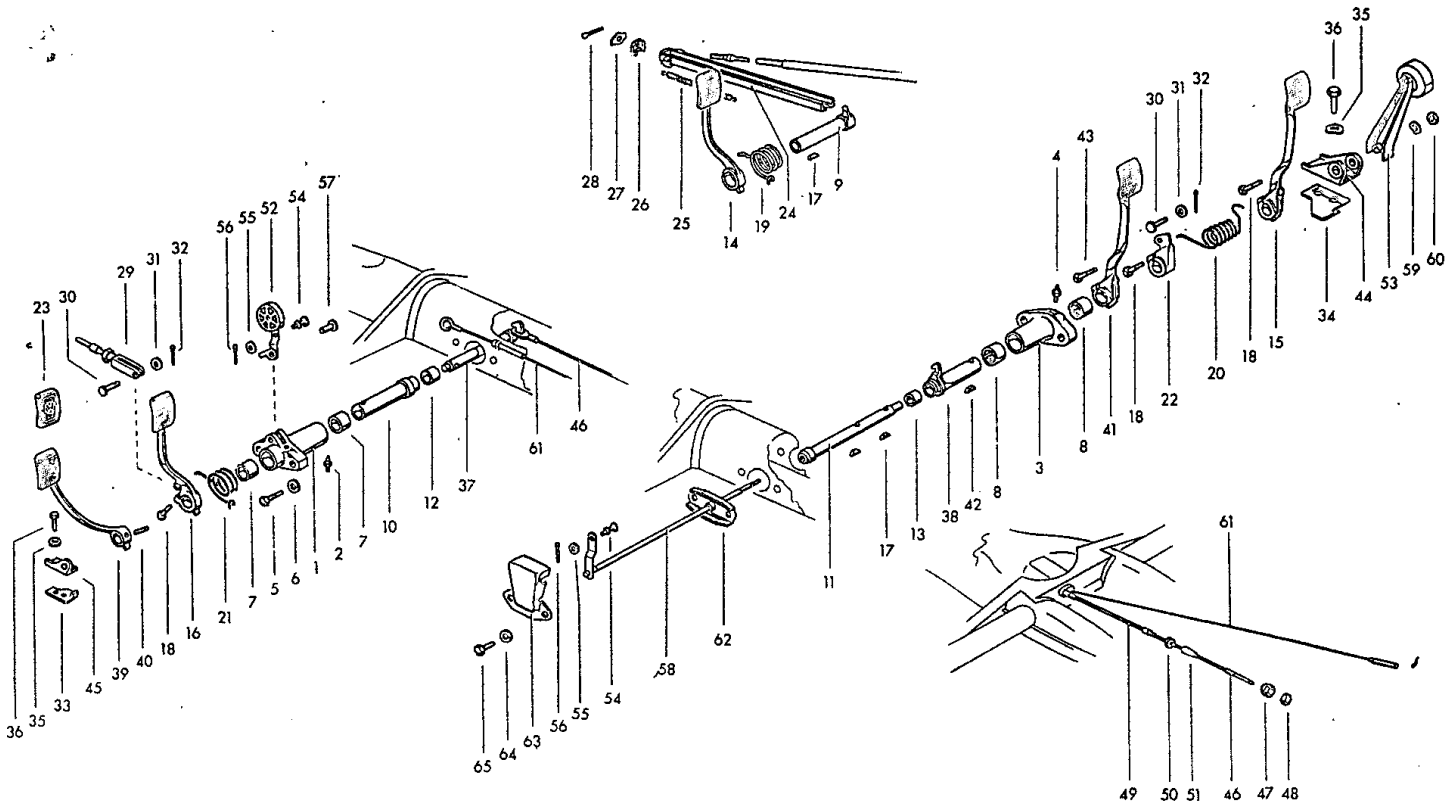



Type 111, 115  
up to Chassis No. 4 630 937

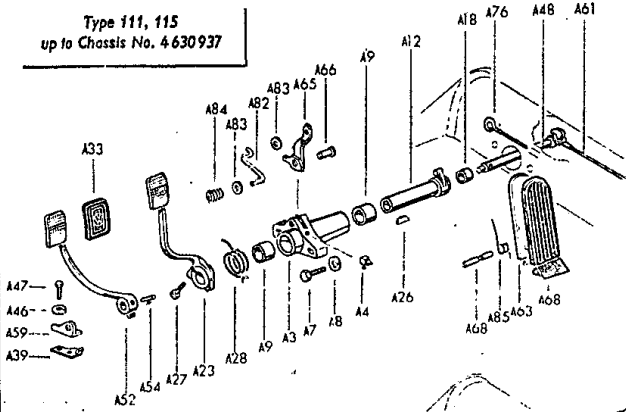

Type 112, 116  
up to Chassis No. 4 630 937

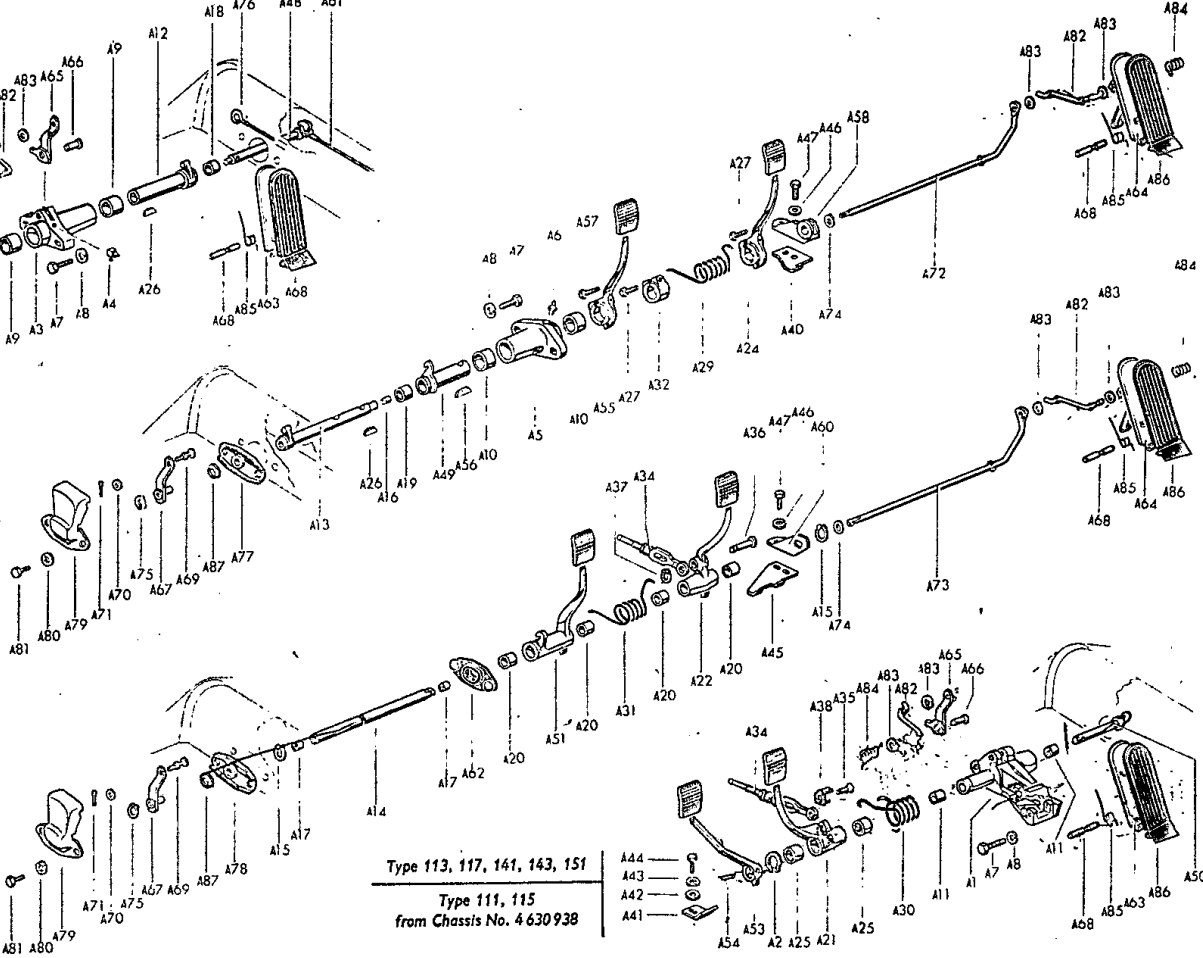

Type 114, 118, 142, 144, 152

Type 112, 116  
from Chassis No. 4 630 938

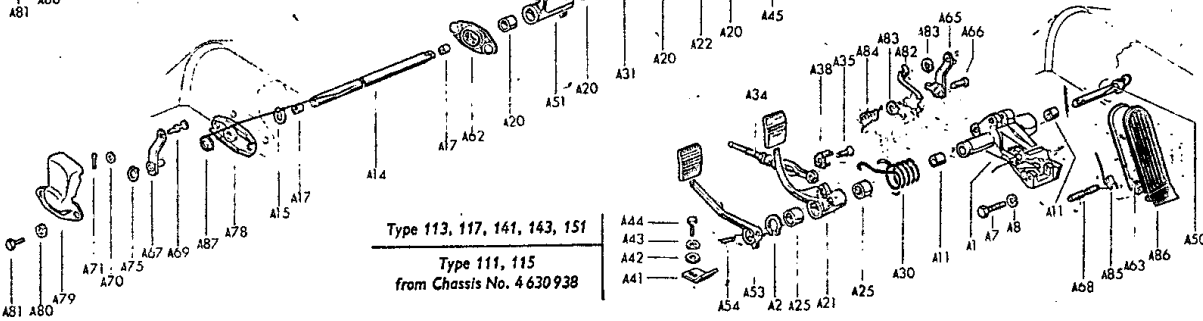

Type 113, 117, 141, 143, 151

Type 111, 115  
from Chassis No. 4 630 938

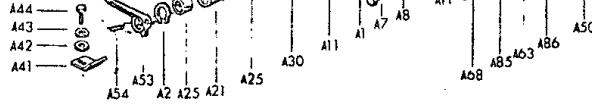





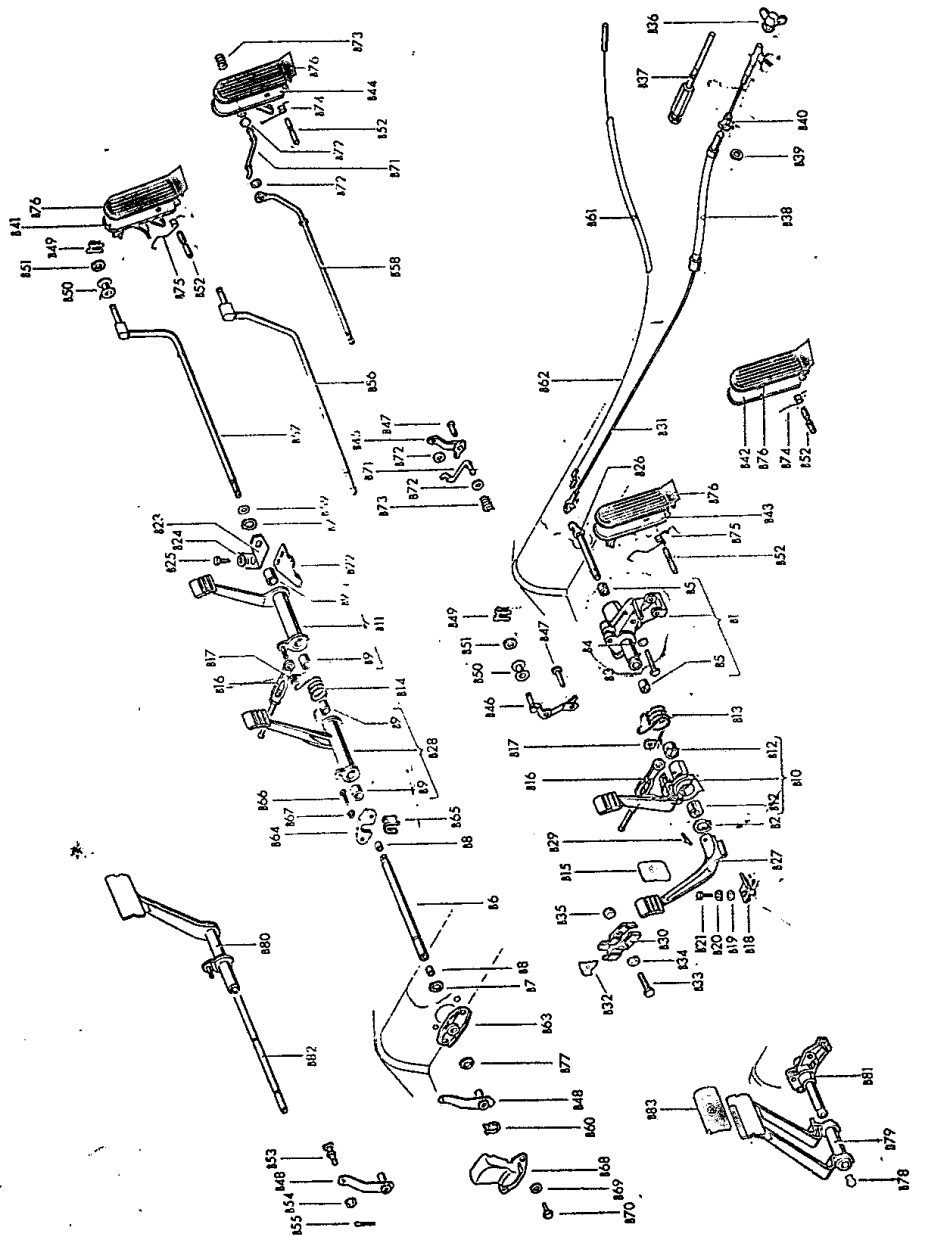

Key No.	Part No.	Description	Quantity	Type and model
		<b>PEDAL CLUSTER</b>		111-118, 141-144, 151, 152
		from Chassis No. 118 071 440		M 9: 113, 114, 117, 118, 141-144, 151, 152
		from Chassis No. 119 000 001		M 9/M 87: 113, 114, 117, 118, 151, 152
		from Chassis No. 110 2000 001		M 9/M 52: 111, 112, 115, 116
		from Chassis No. 111 2000 001		M 1/M 9: 113, 114, 117, 118
-	113 721 071	Pedal bearing ..... from Chassis No. 1 600 440 up to 4 010 994	1	113, 117, 141, 143, 151
A 1/B 1	113 721 071 A	Pedal bearing ..... from Chassis No. 4 010 995 up to 119 421 030	1	111, 113, 115, 117, 141, 143, 151
-	113 721 071 C	Pedal bearing ..... from Chassis No. 119 421 031	1	111, 113, 115, 117, 141, 143, 151
		from Chassis No. 111 2000 001	1	M 1: 113, 117
A 2/B 2	N 12 424 1	Lockring 24 X 1.2 ..... from Chassis No. 111 2000 001	1 1	111, 113, 115, 117, 141, 143, 151 M 1: 113, 117
1	111 721 105	Housing - Brake pedal shaft ..... up to Chassis No. 1 600 439	1	111, 113, 115, 117, 143, 151
A 3	111 721 105 A	Housing - Brake pedal shaft ..... from Chassis No. 1 600 440 up to 4 630 937	1	111, 115
2	N 18 515 1	Grease nipple ..... up to Chassis No. 1 600 439	1	111, 113, 115, 117, 143, 151
A 4	N 18 512 1	Grease nipple C 6 X 1 ..... from Chassis No. 1 600 440 up to 4 010 994	1	111, 113, 114, 115, 117, 118, 141-144, 151, 152
		from Chassis No. 4 010 995 up to 4 630 937	1	111, 115
3/A 5	112 721 105	Housing - Brake pedal shaft ..... up to Chassis No. 1 600 439	1	112, 114, 116, 118, 152
		from Chassis No. 1 600 440 up to 4 630 937	1	112, 116
4	N 18 530 1	Grease nipple A 10 ..... up to Chassis No. 1 600 439	1	112, 114, 116, 118, 152
		from Chassis No. 1 600 440 up to 4 630 937	1	112, 116



Key No.	Part No.	Description	Quantity	Type and model
A 6	N 18 516 1	Grease nipple A 8 ..... up to Chassis No. 1 600 439 from Chassis No. 1 600 440 up to 4 630 937	1 1	112, 114, 116, 118, 152 112, 116
5/A 7/ B 3	N 10 230 3	Bolt, hex. head BM 10X30 ..... from Chassis No. 111 2000 001	2 2	111, 112, 113, 115, 116, 117, 141, 143, 151 M 1: 113, 117
6/A 8/ B 4	N 12 230 2	Spring washer B 10 ..... from Chassis No. 111 2000 001	2 2	111, 112, 113, 115, 116, 117, 141, 143, 151 M 1: 113, 117
-	111 721 113	Bush - Clutch pedal shaft ..... up to Chassis No. 1 - 102 536	2	111, 113
7/A 9	111 721 113 A	Bush - Brake pedal shaft ..... from Chassis No. 1 - 102 537 up to 1 600 439 from Chassis No. 1 600 440 up to 4 630 937	2 2	111, 113, 115, 117, 141, 153 111, 115
8/A 10	112 721 113	Bush - Clutch pedal shaft ..... up to Chassis No. 1 600 439 from Chassis No. 1 600 440 up to 4 630 937	1 1	112, 114, 116, 118, 152 112, 116
-	113 721 113	Bush - Clutch pedal shaft ..... from Chassis No. 1 600 440 up to 4 010 994	2	113, 117, 141, 143, 151
A 11/B 5	311 721 113	Bush - Clutch pedal shaft ..... from Chassis No. 4 010 995 from Chassis No. 111 2000 001	2 2	111, 113, 115, 117, 141, 143, 151 M 1: 113, 117
-	113 721 119	Plug - Pedal cluster bearing ..... from Chassis No. 111 2000 001	2 2	M 9: 113, 117, 141, 143, 151 M 1/M 9: 113, 117
9/A 12	111 721 121	Shaft - Brake pedal ..... up to Chassis No. 4 630 937	1	111, 115
A 13	112 721 121 A	Shaft - Brake pedal ..... up to Chassis No. 4 630 937	1	112, 116
10	113 721 121	Shaft - Brake pedal ..... up to Chassis No. 1 600 439	1	113, 117, 143, 151
11	114 721 121	Shaft - Brake pedal ..... up to Chassis No. 1 600 439	1	114, 118, 152

Key No.	Part No.	Description	Quantity	Type and model
A 14	114 721 121 C	Mounting tube – Pedal cluster ..... from Chassis No. 1 600 440 up to 116 851 649	1	112, 114, 116, 118, 142, 144, 152
B 6	312 721 121 B	Mounting tube – Pedal cluster ..... from Chassis No. 116 851 650	1	112, 114, 116, 118, 142, 144, 152
		from Chassis No. 111 2000 001	1	M 1: 114, 118
A 15/B 7	N 12 418 1	Lockring 18 · 1.2 ..... from Chassis No. 1 600 440	2	112, 114, 116, 118, 142, 144, 152
		from Chassis No. 111 2000 001	2	M 1: 114, 118
A 16	112 721 127	Bush – Accelerator pedal shaft ..... from Chassis No. 1 600 440 up to 4 010 994	1	112, 116
			2	114, 118, 142, 144, 152
A 17/B 8	312 721 127	Bush – Accelerator pedal shaft ..... from Chassis No. 4 010 995	2	112, 114, 116, 118, 142, 144, 152
		from Chassis No. 111 2000 001	2	M 1: 114, 118
12/A 18	111 721 137	Bush – Clutch pedal shaft ..... up to Chassis No. 1 600 439	1	111, 113, 115, 117, 143, 151
		from Chassis No. 1 600 440 up to 4 630 937	1	111, 115
13/A 19	112 721 137	Bush – Brake pedal shaft ..... up to Chassis No. 1 600 439	1	112, 114, 116, 118, 152
		from Chassis No. 1 600 440 up to 4 630 937	1	112, 116
A 20/B 9	312 721 137	Bush – Brake and clutch pedals ..... from Chassis No. 1 600 440	4	112, 114, 116, 118, 142, 144, 152
		from Chassis No. 111 2000 001	4	M 1: 114, 118
-	112 721 141	Pedal – Brake ..... from Chassis No. 116 851 650	1	112, 114, 116, 118, 142, 144, 152
		from Chassis No. 111 2000 001	1	M 1: 114, 118
-	113 721 141	Pedal – Brake ..... from Chassis No. 1 600 440 up to 4 010 994	1	113, 117, 141, 143, 151
A 21	113 721 141 B	Pedal – Brake ..... from Chassis No. 4 010 995 up to 116 851 649	1	111, 113, 115, 117, 141, 143, 151



Key No.	Part No.	Description	Quantity	Type and model
B 10		no longer available		
-	113 721 141 D	Pedal - Brake ..... from Chassis No. 116 851 650 from Chassis No. 111 2000 001 use: from Chassis No. 116 851 650 up to 119 421 030 113 721 071 C/205 J/315 C	1 1	111,113,115,117,141,143,151 M 1: 113, 117
-	114 721 141	Pedal - Brake ..... from Chassis No. 1 600 440 up to 4 010 994	1	114, 118, 142, 144, 152
A 22	114 721 141 B	Pedal - Brake ..... from Chassis No. 4 010 995 up to 116 851 649	1	112, 114, 116, 118, 142, 144, 152
B 11		no longer available		
14/A 23	111 721 151 A	Pedal - Brake ..... up to Chassis No. 4 630 937	1	111, 115
15	112 721 151	Pedal - Brake ..... up to Chassis No. 1 600 439	1	112, 114, 116, 118, 152
A 24	112 721 151 A	Pedal - Brake ..... from Chassis No. 1 600 440 up to 4 630 937	1	112, 116
-	113 721 151	Pedal - Brake ..... up to Chassis No. 1 - 397 022	1	113, 117, 151
16	113 721 151 A	Pedal - Brake ..... from Chassis No. 1 - 397 023 up to 1 600 439	1	113, 117, 143, 151
-	113 721 153	Bush - Brake pedal ..... from Chassis No. 1 600 440 up to 4 010 994	2	113, 117, 141, 143, 151
A 25/B 12	311 721 153	Bush - Brake pedal ..... from Chassis No. 4 010 995  from Chassis No. 111 2000 001	2  2	111, 113, 115, 117, 141, 143, 151 M 1: 113, 117
17/A 26	111 721 157	Woodruff key - Brake pedal shaft ..... up to Chassis No. 1 600 439 up to Chassis No. 4 630 937	2 1	114, 118, 152 111, 112, 115, 116

Key No.	Part No.	Description	Quantity	Type and model
18/A 27	N 10 335 4	Bolt, hex. head M 8×35 up to Chassis No. 1 600 439	1	111, 113, 115, 117, 143, 151
		up to Chassis No. 1 600 439	2	112, 114, 116, 118, 152
		from Chassis No. 1 600 440 up to 4 630 937	1	111, 115
		from Chassis No. 1 600 440 up to 4 630 937	2	112, 116
19/A 28	111 721 163	Return spring – Brake pedal up to Chassis No. 4 630 937	1	111, 115
20/A 29	112 721 163	Return spring – Brake pedal up to Chassis No. 1 600 439	1	112, 114, 116, 118, 152
		from Chassis No. 1 600 440 up to 4 630 937	1	112, 116
21	113 721 163	Return spring – Brake pedal up to Chassis No. 1 600 439	1	113, 117, 143, 151
A 30	113 721 163 A	Return spring – Brake pedal from Chassis No. 1 600 440 up to 116 851 649	1	111, 113, 115, 117, 141, 143, 151
B 13	131 721 163	Return spring – Brake pedal from Chassis No. 116 851 650	1	111, 113, 115, 117, 141, 143, 151
		from Chassis No. 111 2000 001	1	M 1: 113, 117
A 31	114 721 163	Return spring – Brake pedal from Chassis No. 1 600 440 up to 116 851 649	1	112, 114, 116, 118, 142, 144, 152
B 14	132 721 163	Return spring – Brake pedal from Chassis No. 116 851 650	1	112, 114, 116, 118, 142, 144, 152
		from Chassis No. 111 2000 001	1	M 1: 114, 118
A 32	112 721 167	Spacer up to Chassis No. 4 630 937	1	112, 116
22	114 721 171	Brake lever on brake pedal shaft up to Chassis No. 1 600 439	1	114, 118, 152
23/A 33/ B 15	311 721 173 A	Rubber pad – Brake and clutch pedals (cut accordingly for cast pedals)	2	
24	111 721 175	Push bar – Foot brake up to Chassis No. 4 630 937	1	111, 112, 115, 116
25	111 721 191	Return spring – Foot brake push bar up to Chassis No. 4 630 937	1	111, 112, 115, 116

Key No.	Part No.	Description	Quantity	Type and model
26	111 721 195	Cover - Brake cable junction head ..... up to Chassis No. 4 630 937	1	111, 112, 115, 116
27	111 721 199	Plate - Junction head ..... up to Chassis No. 4 630 937	1	111, 112, 115, 116
28	N 12 522 1	Cotter pin 2x22 ..... up to Chassis No. 4 630 937	1	111, 112, 115, 116
29	113 721 205 A	Push rod 7 mm dia. - Master cylinder 19/22 ..... up to Chassis No. 1 600 439 (up to Chassis No. 1 - 575 414 adjust to total length of 155 mm)	1	113, 114, 117, 118, 143, 151, 152
A 34	113 721 205 J	Push rod M 9 - Master cylinder ..... from Chassis No. 1 600 440 up to 116 851 649 from Chassis No. 117 384 751 use: from Chassis No. 1 600 440 up to 116 851 649; 113 611 195 B	1 1	
-	113 721 205 K	Push rod M 9 - Master cylinder ..... from Chassis No. 116 851 650 up to 117 384 750	1	
B 16		no longer available		
B 17	N 12 329 1	Securing washer 9 - Push rod ..... from Chassis No. 116 851 650	1	
30	111 721 219	Bolt - Push rod ..... up to Chassis No. 1 600 439	1	113, 114, 117, 118, 143, 151, 152
A 35	113 721 219	Bolt - Push rod ..... from Chassis No. 1 600 440 up to 116 851 649	1	111, 113, 115, 117, 141, 143, 151
A 36	114 721 219	Bolt - Push rod ..... from Chassis No. 1 600 440 up to 116 851 649	1	112, 114, 116, 118, 142, 144, 152
31	N 11 558 1	Washer 8.4 ..... up to Chassis No. 1 600 439	1	113, 114, 117, 118, 143, 151, 152
32	N 12 512 1	Cotter pin 2x12 ..... up to Chassis No. 1 600 439	1	113, 114, 117, 118, 143, 151, 152
A 37	N 12 411 1	Lockring 11x1 ..... from Chassis No. 1 600 440 up to 115 999 000	1	112, 114, 116, 118, 142, 144, 152





Key No.	Part No.	Description	Quantity	Type and model
-	N 12 329 1	Securing washer 9 ..... from Chassis No. 116 000 001	1	112, 114, 116, 118, 142, 144, 152
A 38	113 721 221	Lock plate - Bolt ..... from Chassis No. 1 600 440 up to 116 851 649	1	111, 113, 115, 117, 141, 143, 151
33/A 39	111 721 231 A	Stop - Brake pedal ..... up to Chassis No. 1 600 439	1	111, 113, 115, 117, 143, 151
		from Chassis No. 1 600 440 up to 4 630 937	1	111, 115
34/A 40	112 721 231	Stop - Brake and clutch pedals ..... up to Chassis No. 1 600 439	2	112, 114, 116, 118, 152
		from Chassis No. 1 600 440 up to 4 630 937	2	112, 116
A 41		no longer available		
-	113 721 231 B	Stop - Brake and clutch pedals ..... (only when using cast pedal cluster on frames from Chassis No. 116 851 650)	x	111, 113, 115, 117, 141, 143, 151
B 18	113 721 231 D	Stop - Brake and clutch pedals ..... up to Chassis 116 851 649	1	111, 113, 115, 117, 141, 143, 151
		from Chassis No. 116 851 650 up to 110 3100 000	1	
-	113 721 231 E	Stop - Brake and clutch pedals ..... from Chassis No. 111 2000 001	1	
A 42/B 19	N 11 654 2	Washer 9,5 ..... from Chassis No. 1 600 440	1	111, 113, 115, 117, 141, 143, 151
35/A 43/ B 20	N 12 241 2	Spring washer B 8x15 ..... up to Chassis No. 1 600 439	2	111, 113, 115, 117, 143, 151
		up to Chassis No. 1 600 439	4	112, 114, 116, 118, 152
		from Chassis No. 1 600 440	1	111, 113, 115, 117, 141, 143, 151
36	N 10 239 0	Bolt, hex. head M 8x18 ..... up to Chassis No. 1 600 439	2	111, 113, 115, 117, 143, 151
		up to Chassis No. 1 600 439	4	112, 114, 116, 118, 152

*STILL IN STOCK*  
*SS 84*  
*(12.721.231E)*

Key No.	Part No.	Description	Quantity	Type and model
A 44/B 21	N 10 238 7	Bolt, hex. head M 8×15 from Chassis No. 1 600 440	1	111, 113, 115, 117, 141, 143, 151
A 45/B 22	114 721 231	Stop - Brake and clutch pedals from Chassis No. 1 600 440 up to 116 581 649	1	112, 114, 116, 118, 142, 144, 152
-	114 721 231 A	Stop - Brake and clutch pedals (only when using cast pedal cluster on frames from Chassis No. 116 851 650)	x	112, 114, 116, 118, 142, 144, 152
B 23	312 721 241	Bracket - Pedal cluster from Chassis No. 116 851 650	1	112, 114, 116, 118, 142, 144, 152
A 46/B 24	131 821 150	Spring washer 8.1×22 from Chassis No. 1 600 440 up to 4 630 937	2	111, 112, 114, 115, 116, 118, 142, 144, 152
		from Chassis No. 4 630 938	2	112, 114, 116, 118, 142, 144, 152
A 47/B 25	N 10 238 7	Bolt, hex. head M 8×15 from Chassis No. 1 600 440 up to 4 630 937	2	111, 112, 114, 115, 116, 118, 142, 144, 152
		from Chassis No. 4 630 938	2	112, 114, 116, 118, 142, 144, 152
-	111 721 305	Shaft - Clutch pedal up to Chassis No. 1 - 397 022	1	111, 113, 115, 117, 151
37/A 48	111 721 305 A	Shaft - Clutch pedal from Chassis No. 1 - 397 023 up to 1 600 439	1	111, 113, 115, 117, 143, 151
		from Chassis No. 1 600 440 up to 4 630 937	1	111, 115
-	111 721 305 B	Shaft - Clutch pedal from Chassis No. September 1971	1	111, 113, 115, 117, 141, 143, 151
38/A 49	112 721 305	Shaft - Clutch pedal up to Chassis No. 1 600 439	1	112, 114, 116, 118, 152
		from Chassis No. 1 600 440 up to 4 630 937	1	112, 116
	113 721 305 A	Shaft - Clutch pedal from Chassis No. 1 600 440 up to 6 465 662	1	111, 113, 115, 117, 141, 143, 151
A 50/B 26	113 721 305 B	Shaft - Clutch pedal from Chassis No. 6 465 663 up to August 1971	1	111, 113, 115, 117, 141, 143, 151

Key No.	Part No.	Description	Quantity	Type and model
-	112 721 315	Pedal - Clutch ..... from Chassis No. 111 2000 001 up to 112 2076 466	1	112, 114, 116, 118, 142, 144, 152
-	112 721 315 A	Pedal - Clutch ..... from Chassis No. 112 2076 467	1	112, 114, 116, 118, 142, 144, 152
B 27	113 721 315 C	Pedal - Clutch ..... from Chassis No. 116 851 650	1	111, 113, 115, 117, 141, 143, 151
B 28	312 721 315 A	Pedal - Clutch ..... from Chassis No. 116 851 650 up to 119 421 030	1	112, 114, 116, 118, 142, 144, 152
-	312 721 315 B	Pedal - Clutch ..... from Chassis No. 119 421 031 up to 110 3100 000	1	112, 114, 116, 118, 142, 144, 152
A 51	114 721 319 A	Pedal - Clutch ..... from Chassis No. 1 600 440 up to 116 851 649	1	112, 114, 116, 118, 142, 144, 152
39/A 52	111 721 321	Pedal - Clutch ..... up to Chassis No. 1 600 439	1	111, 113, 115, 117, 143, 151
		from Chassis No. 1 600 440 up to 4 630 937	1	111, 115
A 53	113 721 321	Pedal - Clutch ..... from Chassis No. 1 600 440 up to 4 630 937	1	113, 117, 143, 151
		from Chassis No. 4 630 938 up to 116 851 649	1	111, 113, 115, 117, 141, 143, 151
40/A 54/ B 29	N 12 834 1	Grooved pin, self-locking 6×30	1	111, 113, 115, 117, 141, 143, 151
41/A 55	112 721 321 A	Pedal - Clutch ..... up to Chassis No. 1 600 439	1	112, 114, 116, 118, 152
		from Chassis No. 1 600 440 up to 4 630 937	1	112, 116
42/A 56	111 721 157	Woodruff key - Clutch pedal shaft ..... up to Chassis No. 1 600 439	-1	112, 114, 116, 118, 152
		from Chassis No. 1 600 440 up to 4 630 937	1	112, 116
43/A 57	N 10 247 3	Bolt, hex. head M 8×35 ..... up to Chassis No. 1 600 439	1	112, 114, 116, 118, 152
		from Chassis No. 1 600 440 up to 4 630 937	1	112, 116
44	112 721 325	Bracket - Accelerator pedal shaft ..... up to Chassis No. 1 600 439	1	112, 114, 116, 118, 152
A 58	112 721 325 A	Bracket - Brake pedal shaft ..... from Chassis No. 1 600 440 up to 4 630 937	1	112, 116

Key No.	Part No.	Description	Quantity	Type and model
45/A 59	111 721 329	Bracket - Pedal cluster from Chassis No. 1 - 397 023 up to 1 600 439	1	111, 113, 115, 117, 143, 151
		from Chassis No. 1 600 440 up to 4 630 937	1	111, 115
A 60	114 721 329	Bracket - Pedal cluster from Chassis No. 1 600 440 up to 116 851 649	1	112, 114, 116, 118, 142, 144, 152
-	114 721 329 A	Bracket - Pedal cluster from Chassis No. 116 851 650	1	112, 114, 116, 118, 142, 144, 152
B 30	113 721 333	Stop - Clutch pedals from Chassis No. 117 384 751 up to 110 3100 000	2	111, 113, 115, 117, 141, 143, 151
46/A 61	111 721 335	Cable - Clutch (2268 mm - 89 <sup>9</sup> / <sub>32</sub> in.) up to Chassis No. 3 192 506	1	
		from Chassis No. 3 192 507 up to 4 010 994	1	111, 112, 115, 116
		from Chassis No. 4 010 995 up to 5 261 829	1	
		from Chassis No. 5 261 830 up to 116 532 999	1	111, 112, 115, 116
-	111 721 335 A	Cable - Clutch (2250 mm - 88 <sup>11</sup> / <sub>32</sub> in.) from Chassis No. 3 192 507 up to 4 010 994	1	113, 114, 117, 118, 141-144, 151, 152
-	111 721 335 C	Cable - Clutch (2281 mm - 89 <sup>13</sup> / <sub>32</sub> in.) from Chassis No. 112 2000 001	1	
-	113 721 335	Cable - Clutch (2258 mm - 88 <sup>29</sup> / <sub>32</sub> in.) from Chassis No. 5 261 830 up to 116 532 999	1	113, 114, 117, 118, 141-144, 151, 152
B 31	113 721 335 A	Cable - Clutch (2260 mm - 88 <sup>31</sup> / <sub>32</sub> in.) from Chassis No. 116 533 000 up to 111 3200 000	1	
B 32	113 721 341	Rubber stop from Chassis No. 117 384 571 up to 110 3100 000	1	111, 113, 115, 117, 141, 143, 151
B 33	N 10 240 4	Bolt, hex. head M 8x20 up to Chassis No. 110 3100 000	1	111, 113, 115, 117, 141, 143, 151
B 34	N 12 241 2	Spring washer B 8x15 up to Chassis No. 110 3100 000	1	111, 113, 115, 117, 141, 143, 151
B 35	N 11 008 8	Nut, hex. M 8 up to Chassis No. 110 3100 000	1	111, 113, 115, 117, 141, 143, 151
-	111 721 349	Adjusting nut M 6 - Clutch cable up to Chassis No. 6 502 399	1	
-	N 11 006 2	Nut, hex. M 6 up to Chassis No. 6 502 399	1	

Key No.	Part No.	Description	Quantity	Type and model
47	111 721 349 A	Adjusting nut M 7 – Clutch cable up to Chassis No. 115 685 586	1	
B 36	131 721 349	Wing nut M 7 – Clutch cable from Chassis No. 115 685 587	1	
48	N 11 007 1	Nut, hex. M 7 up to Chassis No. 115 685 586	1	
B 37	111 721 355	Coupling – Clutch cable up to Chassis No. 111 3200 000	1	
-	111 721 361 B	Sleeve – Clutch cable from Chassis No. 112 2000 001	1	
49/B 38	311 721 361	Sleeve – Clutch cable	1	
50/B 39	111 513 479	Washer	x	
51/B 40	111 721 365	Rubber sleeve – Clutch cable	1	
A 62	114 721 391	Gasket – Pedal cluster from Chassis No. 1 600 440 up to 116 851 649	1	112, 114, 116, 118, 142, 144, 152
B 41	112 721 505 A	Pedal – Accelerator from Chassis No. 116 460 614	1	112, 114, 116, 118, 142, 144, 152
52	111 721 507	Pedal – Accelerator up to Chassis No. 1 600 439	1	111, 113, 115, 117, 143, 151
A 63/B 42	111 721 507 B	Pedal – Accelerator from Chassis No. 1 600 440 up to 116 460 613	1	111, 113, 115, 117, 141, 143, 151
B 43	111 721 507 E	Pedal – Accelerator from Chassis No. 116 460 614	1	111, 113, 115, 117, 141, 143, 151
53	112 721 507	Pedal – Accelerator up to Chassis No. 1 600 439	1	112, 114, 116, 118, 152
A 64/B 44	112 721 507 B	Pedal – Accelerator from Chassis No. 1 600 440 up to 116 460 613	1	112, 114, 116, 118, 142, 144, 152
A 65/B 45	311 721 509	Lever – Accelerator cable connecting from Chassis No. 1 600 440 up to 116 460 613	1	111, 113, 115, 117, 141, 143, 151

Typ 1-5

Illustration **38 + A 38 + B 38**



Key No.	Part No.	Description	Quantity	Type and model
B 46	311 721 509 A	Lever – Accelerator cable connecting ..... from Chassis No. 116 460 614	1	111, 113, 115, 117, 141, 143, 151
A 66/B 47	111 721 517	Bolt 8X18 ..... from Chassis No. 1 600 440	1	111, 113, 115, 117, 141, 143, 151
A 67/B 48	112 721 509 A	Lever – Accelerator cable connecting ..... from Chassis No. 1 600 440	1	112, 114, 116, 118, 142, 144, 152
B 49	311 721 519	Lockwasher – Roller ..... from Chassis No. 116 460 614	1	
B 50	311 721 521	Roller – Accelerator pedal ..... from Chassis No. 116 460 614	1	
B 51	N 11 557 2	Washer 6.4 ..... from Chassis No. 116 460 614	1 2	111, 113, 115, 117, 141, 143, 151 112, 114, 116, 118, 142, 144, 152
A 68/B 52	111 721 525 A	Bolt – Accelerator pedal mounting ..... from Chassis No. 1 600 440	1	
S4/A 69/ B 53	111 721 529 A	Bolt front – Accelerator cable ..... up to Chassis No. 1 600 439 from Chassis No. 1 600 440 up to 116 460 613	1 1	112, 114, 116, 118, 142, 144, 152
S5/A 70/ B 54	N 11 651 1	Washer 5.8 ..... up to Chassis No. 1 600 439 from Chassis No. 1 600 440 up to 116 460 613	1 1	112, 114, 116, 118, 142, 144, 152
S6/A 71/ B 55	N 12 512 1	Cotter pin 2X12 ..... up to Chassis No. 1 600 439 from Chassis No. 1 600 440 up to 116 460 613	1 1	112, 114, 116, 118, 142, 144, 152
-	111 721 535	Bolt with threaded shoulder – Accelerator pedal .. up to Chassis No. 1 600 439	1	111, 113, 115, 117, 151
S7	111 721 535 A	Bolt – Accelerator pedal ..... up to Chassis No. 1 600 439	1	111, 113, 115, 117, 151

Key No.	Part No.	Description	Quantity	Type and model
58	112 721 539	Accelerator pedal shaft ..... up to Chassis No. 1 600 439	1	112, 114, 116, 118, 152
59	N 12 226 2	Spring washer B 6 ..... up to Chassis No. 1 600 439	1	112, 114, 116, 118, 152
60	N 11 006 2	Nut, hex. M 6 ..... up to Chassis No. 1 600 439	1	112, 114, 116, 118, 152
B 56	114 721 539	Accelerator pedal shaft ..... from Chassis No. 116 460 614 up to 116 851 649	1	112, 114, 116, 118, 142, 144, 152
B 57	114 721 539 A	Accelerator pedal shaft ..... from Chassis No. 116 851 650	1	112, 114, 116, 118, 142, 144, 152
A 72	112 721 545 A	Accelerator pedal shaft ..... from Chassis No. 1 600 440 up to 4 630 937	1	112, 116
A 73/B 58	114 721 545	Accelerator pedal shaft ..... from Chassis No. 1 600 440 up to 4 630 937	1	114, 118, 142, 144, 152
		from Chassis No. 4 630 938 up to 116 460 613	1	112, 114, 116, 118, 142, 144, 152
A 74/B 59	N 11 526 2	Washer B 8.4 ..... from Chassis No. 1 600 440	1	112, 114, 116, 118, 142, 144, 152
A 75/B 60	N 12 408 1	Lockring 8×0.8 ..... from Chassis No. 1 600 440	1	112, 114, 116, 118, 142, 144, 152
-	113 721 551	Protective tube - Accelerator cable ..... from Chassis No. 118 000 001 up to 111 3200 000	1	
B 61	131 721 551	Protective tube - Accelerator cable ..... from Chassis No. 116 460 614 up to 117 999 000	1	
-	181 721 551	Protective tube - Accelerator cable ..... (623 mm - 24 <sup>17</sup> / <sub>32</sub> in.) from Chassis No. 112 2000 001	1	
-	111 721 555	Cable - Accelerator (2660 mm - 104 <sup>23</sup> / <sub>32</sub> in.) ..... up to Chassis No. 1 - 397 022	1	
61	111 721 555 A	Cable - Accelerator (2630 mm - 103 <sup>17</sup> / <sub>32</sub> in.) ..... from Chassis No. 1 - 397 023 up to 1 600 439	1	
		from Chassis No. 1 600 439 up to 3 192 506	1	112, 114, 116, 118, 142, 144, 152



Key No.	Part No.	Description	Quantity	Type and model
A 76	111 721 555 C	Cable - Accelerator (2650 mm - 104 <sup>11</sup> / <sub>32</sub> in.) . . . . . from Chassis No. 1 600 440 up to 116 460 613	1	111, 113, 115, 117, 141, 143, 151
B 62	111 721 555 E	Cable - Accelerator (2627 mm - 103 <sup>7</sup> / <sub>16</sub> in.) . . . . . from Chassis No. 116 460 614 up to 111 3200 000	1	111, 113, 115, 117, 141, 143, 151
-	111 721 555 J	Cable - Accelerator (2642 mm - 104 <sup>1</sup> / <sub>32</sub> in.) . . . . . from Chassis No. 112 2000 001	1	111, 113, 115, 117, 141, 143, 151
-	112 721 555	Cable - Accelerator (2650 mm - 104 <sup>11</sup> / <sub>32</sub> in.) . . . . . from Chassis No. 112 2000 001	1	112, 114, 116, 118, 142, 144, 152
-	114 721 555	Cable - Accelerator (2615 mm - 102 <sup>15</sup> / <sub>16</sub> in.) . . . . . from Chassis No. 3 192 507 up to 116 460 613	1	112, 114, 116, 118, 142, 144, 152
-	114 721 555 A	Cable - Accelerator (2635 mm - 103 <sup>3</sup> / <sub>4</sub> in.) . . . . . from Chassis No. 116 460 614 up to 111 3200 000	1	112, 114, 116, 118, 142, 144, 152
-	311 721 579	Rubber sleeve - Accelerator cable . . . . .	1	M 9; M 1/M 9
-	111 711 691	Plug - Accelerator cable . . . . . from Chassis No. November 1971	1	
62	112 721 585	Support - Accelerator pedal shaft (on frame) . . . . . up to Chassis No. 1 600 439	1	112, 114, 116, 118, 152
A 77	112 721 585 A	Bearing - Accelerator lever . . . . . from Chassis No. 1 600 440 up to 4 630 937	1	112, 116
A 78/B 63	114 721 585	Bearing - Mounting tube . . . . . from Chassis No. 1 600 440 up to 4 630 937 from Chassis No. 4 630 938	1 1	114, 118, 142, 144, 152 112, 114, 116, 118, 142, 144, 152
B 64	312 721 587	Cover plate - Mounting tube . . . . . from Chassis No. 116 851 650	1	112, 114, 116, 118, 142, 144, 152
B 65	312 721 591	Seal - Cover plate . . . . . from Chassis No. 116 851 650	1	112, 114, 116, 118, 142, 144, 152
B 66	N 10 249 1	Bolt, hex. head M 10×15 . . . . . from Chassis No. 116 851 650	2	112, 114, 116, 118, 142, 144, 152



Key No.	Part No.	Description	Quantity	Type and model
B 67	N 12 230 2	Spring washer B 10 .....	2	112, 114, 116, 118, 142, 144, 152
		from Chassis No. 116 851 650	2	M 1: 114, 118
		from Chassis No. 111 2000 001	2	M 1: 114, 118
63/A 79/ B 68	112 721 595 A	Cover plate – Accelerator cable .....	1	112, 114, 116, 118, 142, 144, 152
		from Chassis No. 111 2000 001	1	M 1: 114, 118
64/A 80/ B 69	N 12 230 2	Spring washer B 10 .....	2	112, 114, 116, 118, 142, 144, 152
		from Chassis No. 111 2000 001	2	M 1: 114, 118
65/A 81/ B 70	N 10 249 1	Bolt, hex. head M 10 x 15 .....	2	112, 114, 116, 118, 142, 144, 152
		from Chassis No. 111 2000 001	2	M 1: 114, 118
A 82/B 71	111 721 615	Push rod – Accelerator pedal .....	1	
		from Chassis No. 1 600 440 up to 116 851 649		
A 83/B 72	N 11 557 2	Washer 6.4 .....	2	
		from Chassis No. 1 600 440 up to 116 851 649		
A 84/B 73	211 259 283	Spring – Accelerator pedal push rod .....	1	
		from Chassis No. 1 600 440 up to 116 851 649		
A 85/B 74	111 721 619	Return spring – Accelerator pedal .....	1	
		from Chassis No. 1 600 440 up to 116 851 649		
B 75	311 721 619	Return spring – Accelerator pedal .....	1	
		from Chassis No. 116 851 650		
A 86/B 76	113 721 647 A	Rubber pad – Accelerator pedal .....	1	
		from Chassis No. 1 600 440		
A 87/B 77	114 721 699	Spring washer – Accelerator pedal shaft .....	1	112, 114, 116, 118, 142, 144, 152
		from Chassis No. 1 600 440	1	M 1: 114, 118
		from Chassis No. 111 2000 001	1	M 1: 114, 118
B 78	113 721 119	Plug – Pedal cluster bearing .....	2	M 9: 113, 117, 141, 143, 151
		from Chassis No. 111 2000 001	2	M 1/M 9: 113, 117
B 79	113 723 053	Pedal – Brake .....	1	M 9: 113, 117, 141, 143, 151
		from Chassis No. 111 2000 001	1	M 1/M 9: 113, 117
-	311 723 053 A	Pedal – Brake .....	1	M 9: 113, 117, 141, 143, 151
		up to Chassis No. 110 21200 000		143, 151
B 80	312 723 053	Pedal – Brake .....	1	M 9: 114, 118, 142, 144, 152
		from Chassis No. 111 2000 001	1	M 1/M 9: 114, 118



Key No.	Part No.	Description	Quantity	Type and model
B 81	311 723 071	Pedal bearing ..... from Chassis No. 111 2000 001	1 1	M 9: 113, 117, 141, 143, 151. M 1/M 9: 113, 117
B 82	312 723 119	Mounting tube – Pedal cluster ..... from Chassis No. 111 2000 001	1 1	M 9: 114, 118, 142, 144, 152 M 1/M 9: 114, 118
-	311 723 173	Rubber pad – Brake pedal ..... up to Chassis No. 110 21200 000	1	M 9
B 83	311 723 173 A	Rubber pad – Brake pedal ..... from Chassis No. 111 2000 001	1	M 9, M 1/M 9

Part No.	Description	Quantity
<b>REPAIR KITS</b>		
<b>111 798 011</b>	<b>1 set of installation parts for heater operation</b>	
	comprising:	
131 711 665	Stop – Lever .....	1
111 711 712 A	Lever – Heating .....	1
111 711 717	Cable – Heating control .....	1
131 711 741 A	Knob red – Lever .....	1
111 711 749 A	Friction plate .....	2
311 711 751	Friction washer 8.2×20×0.8 .....	2
111 857 779	Sealing washer on floor plate .....	4
111 857 785	Cover bush – Safety belt mounting 043 grey-black .....	4
113 857 797 A	Escutcheon – Safety belt mounting on floor plate 043 grey-black .....	2
111 857 781 A	Escutcheon – Safety belt mounting on frame 043 grey-black .....	2
N 11 118 1	Nut hex. BM 8 .....	1
N 12 162 1	Spring B 16 .....	1
<b>113 798 041 A</b>	<b>1 set of bumper guards for service installation</b>	
	comprising:	
113 707 155 B	Override .....	4
113 707 177	Bow, front .....	1
111 707 199 A	Seal – Override support .....	4
113 707 233	Support front left – Override .....	1
113 707 234	Support front right – Override .....	1
113 707 385 A	Bow rear left .....	1
113 707 386 A	Bow rear right .....	1
113 707 391	Support rear left .....	1
113 707 392	Support rear right .....	1
N 10 350 3	Bolt, hex. head BM 8×50 .....	4
N 10 239 2	Bolt, hex. head M 8×18 .....	6
N 10 330 2	Bolt, hex. head M 8×30 .....	4
N 12 228 2	Lock washer B 8 .....	20

Part No.	Description	Quantity
<b>113 798 053 A</b>	<b>Bumper, front, with guard (fitted)</b>	
	comprising:	
	Bumper with bow, front .....	1
111 707 197 A	Grommet - Bumper bracket .....	2
111 707 199 A	Seal - Overrider support .....	2
111 821 149 A	Washer .....	4
N 10 241 3	Bolt, hex. head M 8×22 .....	2
N 10 330 2	Bolt, hex. head M 8×30 .....	2
<b>113 798 061</b>	<b>1 mounting part set with brackets for front bumper</b>	
	comprising:	
111 707 121	Reinforcement - Bumper .....	4
111 707 135 A	Bracket - Bumper (front, left) .....	1
111 707 136 A	Bracket - Bumper (front, right) .....	1
113 707 191 B	Screw - Bumper .....	2
111 707 197 A	Grommet - Bumper bracket front .....	2
111 821 149 A	Spring washer .....	4
N 10 241 3	Bolt, hex. head M 8×22 .....	4
N 10 269 1	Bolt, hex. head M 8×38 .....	2
N 11 008 8	Nut, hex. M 8 .....	2
N 12 228 2	Spring washer B 8 .....	4
<b>113 798 063</b>	<b>1 mounting part set with brackets for front bumper (bumper guard)</b>	
	comprising:	
111 707 121	Reinforcement - Bumper .....	4
111 707 135 A	Bracket - Bumper (front, left) .....	1
111 707 136 A	Bracket - Bumper (front, right) .....	1
113 707 191 B	Screw - Bumpers .....	2
111 707 197 A	Grommet - Bumper bracket .....	2
111 707 199 A	Seal - Overrider support .....	2
113 707 233	Support, front, left .....	1
113 707 234	Support, front, right .....	1
111 821 149 A	Spring washer .....	4
N 10 239 0	Bolt, hex. head M 8×18 .....	2
N 10 241 3	Bolt, hex. head M 8×22 .....	2
N 10 269 1	Bolt, hex. head M 8×38 .....	2
N 10 330 2	Bolt, hex. head M 8×30 .....	2
N 10 350 3	Bolt, hex. head BM 8×50 .....	2
N 11 008 8	Nut, hex. M 8 .....	2
N 12 228 2	Spring washer B 8 .....	8

Part No.	Description	Quantity
<b>113 798 073 B</b>	<b>Bumper, rear, with guard (fitted)</b>	
	comprising:	
	Bumper with bow, rear .....	1
111 707 197 A	Grommet – Bumper bracket .....	2
111 707 199 A	Seal – Overrider support .....	2
131 821 150	Washer .....	4
N 10 241 3	Bolt, hex. head M 8×22 .....	2
N 10 330 2	Bolt, hex. head M 8×30 .....	2
<b>113 798 081</b>	<b>Bumper, rear, with guard</b>	
	comprising:	
111 707 121	Reinforcement – Bumper .....	4
113 707 191	Screw – Bumper .....	4
111 707 197 A	Grommet – Bumper bracket front .....	2
111 707 335	Bracket – Bumper (rear left) .....	1
111 707 336	Bracket – Bumper (rear right) .....	1
131 821 150	Spring washer .....	4
N 10 241 3	Bolt, hex. head M 8×22 .....	6
N 11 008 8	Nut, hex. M 8 .....	4
N 12 228 2	Spring washer B 8 .....	6
<b>113 798 083</b>	<b>1 mounting part set with brackets for rear bumper (bumper guard)</b>	
	comprising:	
111 707 121	Reinforcement – Bumper .....	4
113 707 191	Screw – Bumper .....	4
111 707 197 A	Grommet – Bumper .....	2
111 707 199 A	Grommet – Support .....	2
111 707 335 B	Bracket – Bumper, left .....	1
111 707 336 B	Bracket – Bumper, right .....	1
113 707 391	Support, rear, left .....	1
113 707 392	Support, rear, right .....	1
131 821 150	Spring washer .....	4
N 10 239 0	Bolt, hex. head M 8×18 .....	4
N 10 241 3	Bolt, hex. head M 8×22 .....	4
N 10 330 2	Bolt, hex. head M 8×30 .....	2
N 10 350 3	Bolt, hex. head BM 8×50 .....	2
N 11 008 8	Nut, hex. M 8 .....	4
N 12 228 2	Spring washer B 8 .....	12



Part No.	Description	Quantity
113 798 085	1 mounting part set with brackets for one bumper from Chassis No. 118 000 001	
	comprising:	
113 707 191 C	Screw M 8×15 .....	6
211 821 149	Spring washer B 8.1×24 .....	12
N 10 239 0	Bolt, hex. head M 8×18 .....	6
N 11 008 8	Nut, hex. M. 8 .....	6

CHASSIS NUMBERS VW 1200/1300 (Type 1) 1.12.47 TO 1.8.72

12.47	1- 072 743	12.59	2 801 613	7.67	117 999 000
12.48	1- 091 921	8.60	3 192 507	8.67	118 000 001
12.49	1- 138 554	12.60	3 551 044	12.67	118 431 603
12.50	1- 220 133	8.61	4 010 995	7.68	118 1016 100
12.51	1- 313 829	12.61	4 400 051	8.68	119 000 001
10.52	1- 397 023	8.62	4 840 836	12.68	119 474 780
12.52	1- 428 156	12.62	5 225 042	7.69	119 1200 000
3.53	1- 454 951	8.63	5 677 119	8.69	110 2000 001
1.54	1- 575 415	12.63	6 016 120	12.69	110 2473 153
12.54	1- 781 884	7.64	6 502 399	7.70	110 3100 000
8.55	1- 929 746	8.64	115 000 001	8.70	111 2000 001
12.55	1 060 929	12.64	115 410 000	12.70	111 2427 591
12.56	1 394 119	7.65	115 999 000	7.71	111 3200 000
8.57	1 600 440	8.65	116 000 001	8.71	112 2000 001
10.57	1 673 411	12.65	116 463 103	12.71	112 2427 792
12.57	1 774 680	7.66	116 1021 300	7.72	112 3200 000
12.58	2 226 206	8.66	117 000 001	8.72	113 2000 001
8.59	2 528 668	12.66	117 442 503		

CHASSIS NUMBERS TYPE 2 1200/1500 12.53 TO 8.65

10.52	20-035 112	6.60	614 456	8.64	215 000 001
3.53	20-047 102	8.61	802 986	7.65	215 176 339
12.53	20-069 409	8.62	971 550	8.65	216 000 001
3.55	20-117 902	1.63	1 041 014	8.66	217 000 001
8.58	374 811	8.63	1 144 282	7.67	217 148 459
6.59	469 506	7.64	1 328 871		

1. The first part of the document discusses the importance of maintaining accurate records of all transactions. It emphasizes that proper record-keeping is essential for the integrity of the financial system and for the ability to detect and prevent fraud. The text notes that without reliable records, it would be difficult to track the flow of funds and identify any irregularities.

2. The second part of the document outlines the various methods used to collect and analyze data. It describes the process of gathering information from different sources, such as interviews, surveys, and document reviews. The text also discusses the importance of ensuring the accuracy and reliability of the data collected, and the need to use appropriate statistical techniques to analyze the results.

3. The third part of the document focuses on the role of the auditor in the process. It describes the responsibilities of the auditor, including the need to maintain independence and objectivity, and to follow established standards and procedures. The text also discusses the importance of communication and reporting, and the need to provide clear and concise information to the relevant parties.

4. The fourth part of the document discusses the challenges faced by auditors in the current environment. It notes that the increasing complexity of financial transactions and the use of new technologies have made the auditing process more difficult. The text also discusses the need for auditors to stay up-to-date on the latest developments in the field, and to have the necessary skills and expertise to handle these challenges.

5. The fifth part of the document discusses the importance of transparency and accountability in the auditing process. It notes that the public has a right to know how the financial system is being managed, and that auditors have a responsibility to provide this information in a clear and accessible way. The text also discusses the need for strong governance and oversight, and the importance of ensuring that the auditing process is subject to regular review and evaluation.

6. The sixth part of the document discusses the role of the auditor in promoting the integrity of the financial system. It notes that auditors play a key role in identifying and reporting any irregularities, and in helping to prevent and detect fraud. The text also discusses the importance of the auditor's independence and objectivity, and the need to maintain high standards of professional conduct.

7. The seventh part of the document discusses the future of auditing. It notes that the use of new technologies, such as artificial intelligence and data analytics, is likely to have a significant impact on the auditing process. The text also discusses the need for auditors to adapt to these changes, and to have the necessary skills and expertise to handle the challenges of the future.